



Part 1.

LEADING PARTICULARS.

GENERAL.

Name.	...	Marathon I.
Type.	...	M.60.
Duty.	...	Passenger/Freighter.
Crew.	...	Two.
Accommodation.	...	Up to a maximum of 22 passengers.

MAIN DIMENSIONS.

See Illustration No.2. "General Arrangement"

AREAS AND CONTROL SURFACES.

Main Plane.

Gross Area.	...	498 sq. ft.	44 m ² 31.
Nett Area.	...	426 sq. ft.	39 m ² 61.
(Gross minus area covered by fuselage. Engine nacelles not considered)			

Flaps.

Type.	...	Retractable, Auxiliary Aerofoil.
Area, per side.	...	32.9 sq. ft. 3 m ² 06.
Span, per side.	...	17 ft. 4.8 in. 5.30 m.

Ailerons.

Type.	...	Round Nose with Geared Tab.
Area, aft of hinge.	...	30.2 sq. ft. 2 m ² 81.

Tail Plane and Elevator.

Gross area, Total.	...	99 sq. ft.	9 m ² 21.
Nett Area.	...	88 sq. ft.	8 m ² 18.
Elevator Balance.	...	Inset Hinge with Geared Tab.	
Elevator Area gross. (Unshrouded)	...	39.13 sq. ft.	3 m ² 64.



Elevator Area gross. ... 29.6 sq. ft. 2 m² 75.
(aft of hinge)

Fin and Rudder.

Gross Area. ... 104 sq. ft. 9 m² 67
Rudder Balance. ... Shielded Horn Balance with Geared Tab.
Rudder Area, gross. ... 27 sq. ft. 2 m² 51.
Rudder Area, (aft of hinge line). ... 24.9 sq. ft. 2 m² 31.

ALIGHTING GEAR.

Main Wheel Units.

Type. ... Separate, Retractable.
Shock-absorber. ... Oleo pneumatic.
Fluid. ... To British A.M. Spec D.T.D.585.
Air Pressure. ... See graph given on illustration Fig.27
Fluid Content ... 3.47 pints.
Wheels. ... Palmer. Type 868 B. Mk.II
Tyres.
Outer Covers. ... Palmer P.B.E.69.
Inner Tubes. ... Palmer P.B.70.
Tread. ... Patterned.
Air Pressure. ... 59 lb. sq. in.
Brakes. ... Palmer 868/50.P.

Nose Wheel Unit.

Type. ... Retractable, Steerable and Self-centring.
Shock-absorber. ... Oleo Pneumatic.
Fluid. ... To British A.M. Spec D.T.D.585.
Air Pressure. ... See graph given on illustration Fig.28.
Fluid Content. ... 5 1/8 pints.

MARATHON I

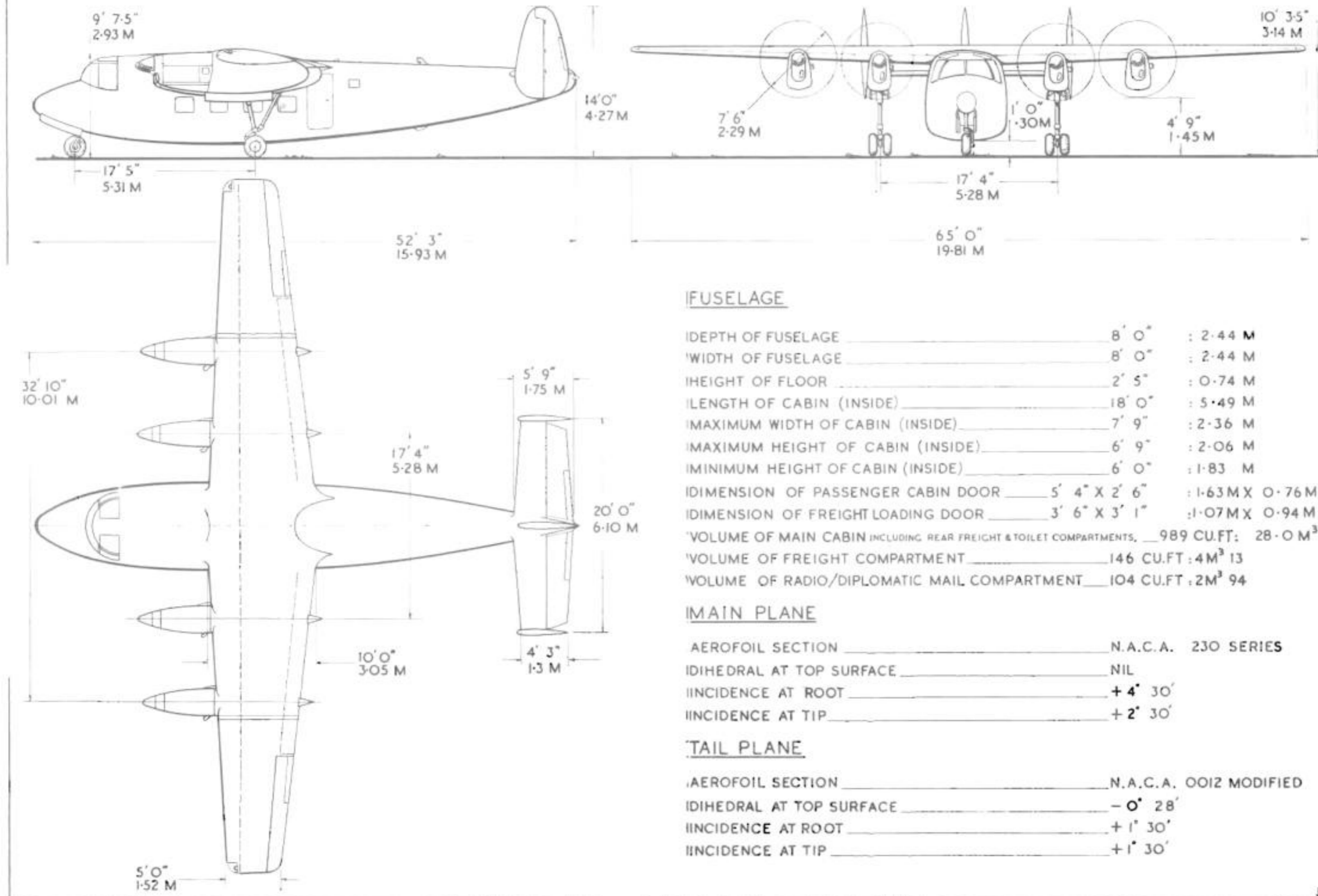

FUSELAGE

DEPTH OF FUSELAGE	8' 0"	: 2.44 M
WIDTH OF FUSELAGE	8' 0"	: 2.44 M
HEIGHT OF FLOOR	2' 5"	: 0.74 M
LENGTH OF CABIN (INSIDE)	18' 0"	: 5.49 M
MAXIMUM WIDTH OF CABIN (INSIDE)	7' 9"	: 2.36 M
MAXIMUM HEIGHT OF CABIN (INSIDE)	6' 9"	: 2.06 M
MINIMUM HEIGHT OF CABIN (INSIDE)	6' 0"	: 1.83 M
DIMENSION OF PASSENGER CABIN DOOR	5' 4" X 2' 6"	: 1.63 M X 0.76 M
DIMENSION OF FREIGHT LOADING DOOR	3' 6" X 3' 1"	: 1.07 M X 0.94 M
VOLUME OF MAIN CABIN INCLUDING REAR FREIGHT & TOILET COMPARTMENTS	989 CU.FT.	: 28.0 M ³
VOLUME OF FREIGHT COMPARTMENT	146 CU.FT.	: 4 M ³ 13
VOLUME OF RADIO/DIPLOMATIC MAIL COMPARTMENT	104 CU.FT.	: 2 M ³ 94

MAIN PLANE

AEROFOIL SECTION	N.A.C.A. 230 SERIES
DIHEDRAL AT TOP SURFACE	NIL
INCIDENCE AT ROOT	+ 4° 30'
INCIDENCE AT TIP	+ 2° 30'

TAIL PLANE

AEROFOIL SECTION	N.A.C.A. 0012 MODIFIED
DIHEDRAL AT TOP SURFACE	- 0° 28'
INCIDENCE AT ROOT	+ 1° 30'
INCIDENCE AT TIP	+ 1° 30'

GENERAL ARRANGEMENT

41
FIG. 2

PART 1.



LEADING
PARTICULARS.

Wheel. ... Palmer. Type 868.
Tyre.
Outer Cover. ... Palmer P.B.E.67.
Inner Tube. ... Palmer P.B.70.
Air Pressure. ... 59 lb. sq. in.

ENGINES.

Name. ... Gipsy Queen Series 70-2.
Number. ... Four.
Type. ... Six-cylinder, inverted, air cooled,
geared and supercharged.
Identification ... Numbered 1, 2, 3 and 4 from left
to right; i.e. number 1 is left
hand outboard.

ENGINE ACCESSORIES.

Vacuum Pumps. ... Two.
Type. ... B.3X. Mk.II.
Driven by Engine Nos. ... 1 and 4.
Generators. ... Two or three according to type.
Type. ... Newton H.X.2.
Driven by Engine Nos. ... 2 and 3.

OR

Type. ... Rotax B.2001.
Driven by Engines Nos. ... 2, 3, and 4.
Compressors. ... Two.
Type. ... Hymatic SH.6/7.
Driven by Engines Nos. ... 1 and 4.
Starting Motor and Feather-
ing Motor. ... Four.
Type. ... Rotax C.4602 combined starting
and feathering motor.
Driven by Engine Nos. ... 1, 2, 3 and 4.

LEADING
PARTICULARS.



PART I.

Feathering Pump.	... Four.
Type.	... de Havilland P.D.F.P/236
Driven by Engines Nos.	... 1, 2, 3 and 4.
Constant Speed Unit.	... Four.
Type.	... de Havilland C.A.Y.30,004.
Driven by Engines Nos.	... 1, 2, 3, and 4.

PROPELLERS.

Type.	... de Havilland, three bladed, constant speed, braking and feathering.
Type No.	... 3/1000/2.
Drawing No.	... CD.103/312/1 or CD.83/312/1 or CD/83/312/2.
Diameter.	... 7 ft. 6 in. 2.286 m.
Rotation.	... Left hand tractor (anti-clockwise when viewed from the rear).
Gear Ratio.711.

TANK CAPACITIES.

Fuel.

Four flexible, crashproof tanks.

Capacity of each tank.	... 55 gallons (Imp.)
Total capacity.	... 220 gallons (Imp.)

Note. Provision is made for the fitment of four auxiliary tanks.

Capacity of each auxiliary tank.	... 15 gallons. (Imp.)
----------------------------------	------------------------

Total capacity with auxiliary tanks fitted.	... 280 gallons. (Imp.)
---	-------------------------

Usable Fuel.	... All fuel is usable with the exception of approx. 1.
--------------	---



Oil.

Four Aluminium Tanks.	
Capacity of each tank.	... 7 $\frac{3}{4}$ gallons. (Imp.)
Engine oil capacity. (per tank).	... 5 gallons. (Imp.)
Feathering Reserve. (per tank).	... 1 gallon. (Imp.)
Air Space (per Tank).	... 1 $\frac{3}{4}$ gallons. (Imp.)
Total Usable Engine Oil.	... 20 gallons. (Imp.)

ELECTRICAL INSTALLATION.

Wiring.	... Single pole, earth return.
Supply.	... Two 24 volt, 1000 watt, or three 24 volt, 750 watt engine driven generators, charging two 12 volt, 40 amp. hr. accumulators connected in series.

PNEUMATICS.

System (Storage) Pressure	... 600 lb/Sq. in.
Undercarriage operation pressure.	... 450 lb/Sq. in.
Flaps (Main and Emergency) pressure.	... 450 lb/Sq. in.
Brake relay valve pressure.	... 220 lb/Sq. in.
Engine air intake shutter jack pressure.	... 220 lb/Sq. in.
Fuel priming pressure.	... 220 lb/Sq. in.
Windscreen wiper pressure.	... 220 lb/Sq. in.
Wheel brakes.	... 0 to 180 lb/sq. in.



Part 8.

POWER PLANTS.

D E S C R I P T I O N .

GENERAL. - See Illustration No. 48.

The aircraft is powered by four Gipsy Queen series 70-2 six-cylinder, in-line, air-cooled, supercharged aero-engines which are part of four detachable power plants.

Each power plant consists of a triangular tubular steel engine mounting, an oil tank and pipelines, the upper portion of the fireproof bulkhead (the lower portion of the bulkhead is part of the engine nacelle), a cowling mounting structure, a complete engine cowling and an engine complete with accessories.

Each plant may, after removing certain cowling panels, be removed as a complete unit by breaking the bulkhead connections of pipes, cables and controls and removing four attachment bolts.

ENGINE MOUNTING.

Each engine mounting consists mainly of two braced triangular frames constructed from welded steel tubing and provided with eye-end attachments by means of which they are bolted to the airframe lugs. The frames are similar in construction but are "handed", each frame consisting of a horizontal upper member, an inclined lower member and two bracing members. The left and right hand frames are held in position by a horizontal bracing member positioned between the rear ends of the frames and by tubular bracing members which extend from the horizontal member to each frame upper member.



Four engine mounting feet which incorporate rubber bonded bushes are each attached to the engine by four studs and are accommodated, at the engine rear feet by a distance tube attached to the forward bracing member of each mounting side frame, and at the engine front feet by a spigot attached to the forward end of each frame.

The engine mounting is so aligned that the thrust line is horizontal $\pm 0^{\circ}20'$, and parallel to the centre-line of the aircraft $\pm 0^{\circ}20'$, also the centre-line of each engine (viewed from the front) is inclined at an angle of $6^{\circ} \pm 10'$ to the vertical.
40

COWLING MOUNTING STRUCTURE AND ENGINE COWLINGS.

The six engine cowling panels are secured by "Oddie" fasteners to the rails of the cowling mounting structure. The nose cowling is bolted to brackets carried on the forward end of the engine mounting and is further secured by the mounting structure side and top rails.

The mounting structure consists of light alloy channel section rails bolted to a nose cowling rail at the front end, and carried on brackets attached to the engine mounting; further support is given, when the power plant is installed, by the rails being bolted to the fireproof bulkhead rail.

The rails are positioned two at the left hand and three at the right hand side of the engine mounting, with a central top rail and a vertical rail at each side.

The top cowling, comprising two panels hinged about the mounting centre rail, embodies two stays which support the panels in the open position; the left hand panel incorporates a louvre through which air enters for cooling the air compressor and/or generator.

The right hand side panel incorporates a "knock-in" fire panel and the left hand panel, which is in two parts, embodies an air intake which is provided with a "momentum" type cleaner and a "gapless" type ice guard.

The bottom panel carries the cowl gill or engine cooling shutter which is hinged to its rear end.

The nose cowling, which completely encloses the front end of the engine, has three apertures. The top aperture permits passage of air to the oil cooler, a small inspection hole, covered with a rubber bung, provides access to the engine timing pointer and a lower aperture directs cooling air to the cylinders. At the right hand side of the cowling, adjacent to the lower aperture, a hinged door allows for inspection of the constant speed unit.

FIREPROOF BULKHEAD.

Mounted in the nacelle structure, each bulkhead consists of a metal sheet diaphragm with facial stiffeners and stiffening members around the periphery; these peripheral members also serve as cowling rails. The upper portion of the bulkhead is detachable and is joined to the lower portion by

KEY TO Fig 48.POWER PLANT ILLUSTRATION.

- | | |
|---|---|
| 1. Cylinder head temperature thermo couple plug. | 20. Compressor. |
| 2. Electric cable socket "B". | 21. Generator. |
| 3. Electric cable socket "A". | 22. Vacuum Pump. |
| 4. Propeller control fireproof box. | 23. Jury rig securing upper bulkhead. |
| 5. Fuel feed pipe bulkhead connection. | 24. Vacuum pump pressure pipe. |
| 6. Slow-running cut-out cable. | 25. Vent pipe from oil tank. |
| 7. Throttle control fireproof box. | 26. Six-way junction box for fire extinguisher pipes. |
| 8. Electric cable socket "D". | 27. Anti-surge valve pipe to oil cooler return pipe. |
| 9. Electric cable socket "E". | 28. Return pipe from oil cooler. |
| 10. Engine mounting attachments. | 29. Magnetos. |
| 11. Earth wire to bulkhead. | 30. Cowling mounting structure. |
| 12. Boost pipe and bulkhead connection. | 31. Upper (hinged) cowling panel. |
| 13. Electric cable plug "E" to socket "E". | 32. Ignition harness. |
| 14. Electric cable plug "D" to socket "D". | 33. Relief valve. |
| 15. Oil tank. | 34. Oil cooler. |
| 16. Electric cable plug "B" to socket "B". | 35. Upper cowling panel stays. |
| 17. Oil tank cradle. | 36. Nose cowl. |
| 18. Upper (removeable) portion of fireproof bulkhead. | 37. Engine mounting structure. |
| 19. Electric cable plug "A" to socket "A". | 38. Engine rear mounting foot. |
| | 39. Cowling lower panel. |
| | 40. Cylinder head temperature thermo-couple. |



- | | |
|---|---|
| 41. Teleflex propeller control. | 50. Propeller de-icing pipe. |
| 42. Flexible feed pipe to fire extinguisher six-way junction box. | 51. Vacuum pump suction pipe. |
| 43. Cooling gill actuator attachment. | 52. Electric cable plug "C" to socket "C". |
| 44. Cooling gill. | 53. Ignition switch cable plug and socket. |
| 45. Cooling gill actuator. | 54. Compressor pipe. |
| 46. Fuel feed pipe. | 55. Engine air intake shutter control pneumatic pipe. |
| 47. Cooling shutter position indicator transmitter cable. | 56. Vacuum suction pipe bulkhead connection. |
| 48. Cooling shutter actuator cable. | 57. Vacuum pump pressure pipe bulkhead connection. |
| 49. Priming pipe. | |

MARATHON I

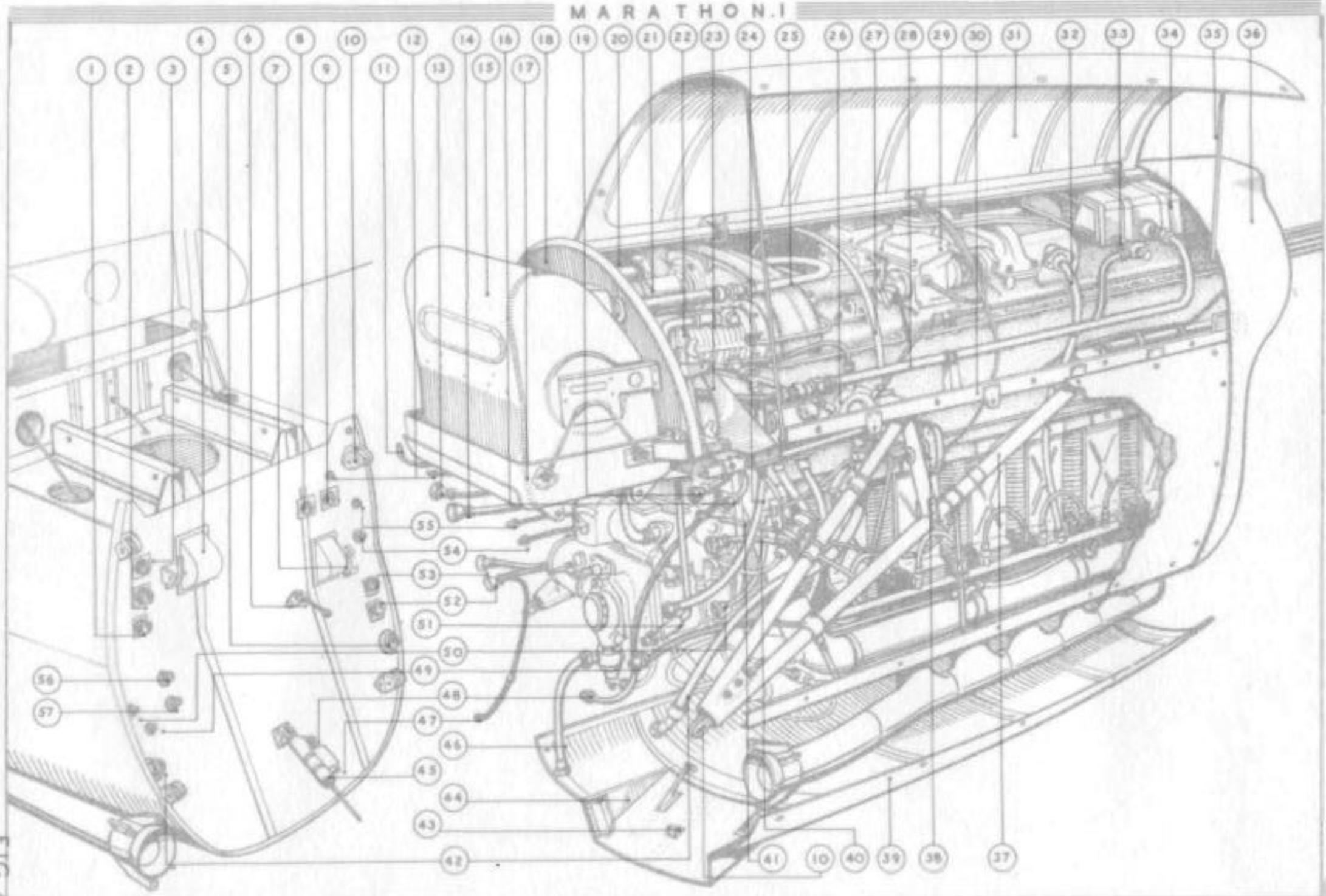

POWER PLANT

FIG. 48

88A



bolts and anchor nuts, it supports the oil tank mounting and facilitates removal of the power plant which may be taken out complete with oil tank, piping system and the upper portion of the bulkhead.

EXHAUST SYSTEMS.

The exhaust pipe system of each engine is similar. Six stainless steel stub pipes of tapering dimensions are socketed together to form a manifold. From each stub pipe a flanged branch pipe extends between the cowling rails to the engine cylinder exhaust ports. An extension pipe is socketed into the rear end of the manifold, and to the extension pipe an ejector pipe is fitted. The ejector pipe serves as a flame damper, has a spring-loaded connection to the extension pipe and is attached to the nacelle through an articulated fitting to allow for expansion and engine movement.

ACCESSORIES.

Engine driven accessories which provide power for the aircraft services are as follows:-

Accessory	Engine No.			
	1.	2.	3.	4.
Type B.3X. Mk.II. Vacuum Pump.	1			1
Type H.X.2. Generator.		1	1	
or				
Rotax Type B.2001 Generator.		1	1	1
Hymatic SH.6/7 Compressor.	1			1
Rotax Type G.4602 Combined Starting and Feathering Motor.	1	1	1	1
de Havilland PDEF/23 Feathering Pump.	1	1	1	1
de Havilland Type CAY.30004 Constant Speed Unit	1	1	1	1

ACCESSORY MOUNTINGS AND DRIVES.

Vacuum Pumps.

The Pesco B.3X Mk.II Vacuum pumps, which are fitted to the outboard engines only, are secured through their flanged mountings and six studs and nuts to the right hand drive housings of the engine accessories drives boxes, situated, one at the rear of each engine. The drive to each pump is transmitted via a short splined coupling shaft, the drive ratio being 1.29 to 1.

Generators.

The generators may be two H.X.2. (1000 watt) fitted to the inboard engines only, or three Rotax B.2001. (750 watt) fitted to the inboard engines and to the right hand outboard engine. In each case the method of drive and mounting is similar. Each generator is secured through its mounting flange and four studs and nuts to the centre drive housing of the engine accessories drives box. The drive is transmitted via a splined shaft, which is fitted to the generator armature spindle, the drive ratio is 2.09 to 1.



Compressors.

The Heywood type SH6/7 compressors, which are fitted to the outboard engines only, are secured through their flanged mountings and six studs and nuts to the left hand drive housings of the engine accessories drives boxes. The drive is transmitted direct to the compressor splined spindle which fits into the splined engine driving gear, the drive ratio is 0.55 to 1.

Starting and Feathering Motors.

The Rotax type C.4602 Combined starting and feathering motors are supplied by the manufacturers as complete units, the feathering motors being mounted on and driven by the starters. Each starter is mounted on the back of the engine in line with the crankshaft which it turns and is secured by six studs and nuts.

Feathering Pumps.

The de Havilland EDPF/23 Feathering pumps are each mounted direct to one of the combined starting and feathering motors. The pumps are secured by four bolts and nuts, alignment being maintained between pump and motor by a spigot on the pump which fits into a recess on the motor. The drive is via the motor splined shaft.

Constant Speed Units.

The de Havilland type CAY.30004 constant speed units are each mounted at the front underside of the engine crankcase, adjacent to the front cylinder, and are each secured by four studs and nuts. The drive is transmitted by female splines in the lower end of the engine drive quillshaft which engage with corresponding splines on the C.S.U. spindle.

Cylinder Head Thermocouple.

A thermo-couple for a cylinder head temperature gauge is connected to the rear cylinder on each engine. The thermo-couple boss is situated just under the right hand sparking plug.

INTERCHANGEABILITY OF POWER PLANTS.

The power plants, except for certain accessories, are completely interchangeable. Each plant may therefore, provided that accessories are changed over to the positions shown above, be used in any nacelle.

ENGINE AND PROPELLER CONTROLS. - See Illustrations Nos. 49, 113 and 114.

Hand Control Box.

The throttle and propeller levers, the cowl gill switches and the slow running cut-out controls are housed in a hand control box which is situated in the centre of the pilot's compartment.

The throttle levers are mounted on a common shaft at the front of the control box and operate in slots which are cut in the box cover; each lever is straight and carries a knob at its upper end. The propeller levers operate in slots cut in the cover at the rear of the box and are mounted on a common shaft. Below the propeller levers are the cowl gill switches, the slow running cut-out knobs being mounted aft of the latter. The cowl gill switches are moved UP to open the gills while the slow running cut-out knobs are pulled upward to STOP the engines.



Two friction clamping devices, one for the throttle levers and one for the propeller levers, are fitted to the hand control box. The dampers prevent movement of the levers due to vibration, are controlled by small hand wheels, and incorporate Ferodo pads which should be kept free from oil and grease.

Stops are provided at the maximum and minimum r.p.m. positions for the four propeller levers, the minimum r.p.m. stops being adjustable. Movement of each propeller lever is as follows:-

UP	to increase r.p.m.
DOWN	to decrease r.p.m.
Fully DOWN	to Feather.
Fully UP	to Brake. (only in the cases where the braking mechanism of the propellers is utilised, and then only on the inboard engines).

Although all four propellers are equipped internally for braking, the mechanism is not so far utilised. When the braking mechanism is used, a full description of the system will be issued as an amendment to this manual.

Throttle Control.

Throttle control is effected by a system of cables, pulleys, rods and levers. Cables pass from the throttle levers to the bottom of the hand control box where they pass over pulleys and extend aft and up between the webs of a box structure at frame 5. Continuing aft along the roof of the fuselage, and after passing over pulleys mounted at frame 14, the cables spread across the fuselage into the main plane, extend through the main plane to each nacelle, and are finally secured to a pulley (inboard) and a quadrant (outboard) mounted on the 10% frame. A control rod extends from a lever on each pulley shaft, and from a plate on each quadrant, through the bulkhead to the upper of two levers mounted on a shaft at the front face of each bulkhead; a further control rod passes from the lower of the two levers to the engine. The upper lever and shaft and the forward end of the control rod are encased in a fireproof metal cover secured to the bulkhead. All control rods are adjustable and are fitted with end ball joints having suitable screw adjustment to take up wear. The cables are adjusted by means of turnbuckles situated at accessible positions in the fuselage. Access to the cables at frame 5 is through inspection panels which are bolted to the front face of the box structure.

Slow Running Cut-Outs.

The slow running cut-outs are cable operated, movement being controlled by four knobs in the hand control box; the control runs follow paths similar to those of the throttle controls. Each control knob is connected to the upper of two levers in the aft end of the control box, and cables, passing over pulleys, extend from the lower levers through the fuselage to frame 13. At this point, the right hand inboard and outboard cables are secured to levers mounted on the lower end of a shaft, and from similar levers mounted on the upper end of the shaft further cables extend to the respective nacelles. Both of these cables then extend to the nacelle 10% frames, the inboard cable being secured to a shackle from which a Bowden cable passes, through the 10% frame and the nacelle to the engine lever.



The outboard cable extends to a bracket on the 10% frame, and from a shackle, secured to the bracket, a Bowden cable passes to the engine lever. The run of the left hand inboard control is similar in all respects to the right hand inboard control. The left hand outboard control passes over a pulley at frame 13, otherwise the run and layout is similar to the right hand outboard control.

The engine levers are spring loaded and the cables are adjustable through turnbuckles and Bowden adjusters.

Engine Cowl Gills.

The engine cowl gills are operated by linear electric actuators controlled from switches mounted in the hand control box. Each actuator has an adjustable ram end and is mounted at the lower end of the bulkhead. Position indicators, mounted on the instrument panel, are operated by transmitters interconnected with the actuators.

Propeller Controls.

The propeller controls are similar in layout to the throttle controls as far as the bulkheads, the cables extending to a pulley in both outboard and inboard nacelles. From the bulkhead lever a teleflex control extends to one arm of a bell crank lever at the front of the engine, a control rod passing from the other arm of the lever to the constant speed unit.

AIR INTAKE - See Illustration No.50.

A 'Sheltered' type engine air intake, fitted with a 'gapless' type ice guard, is fitted to the cowling side panel at the left hand side of the power plant.

The intake consists of a faired body incorporating a front air entry over which a gapless type ice guard is fitted, and a rear entry in the form of sheltered louvres. Inside the body a separate air intake box is fitted, entry to the box being via the front air entry in the body or via an aperture in the side of the box. A shutter, operated by a pneumatically controlled ram, enables the pilot to close either of the two air entries at will.

The operation of the intake is as follows; reference should be made to the illustration.

- (1) In this view, the intake is shown with the ram retracted, the air entry in the side of the air intake inner box is closed by the shutter, and air enters from the front of the intake via the ice guard.
- (2) Here, the pilot has operated the air intake control, the ram has extended and the shutter has swung downward and forward, blanking off the front air entry. Air now enters from the 'sheltered' louvres in the side of the faired body through the side entry in the air intake inner box (now uncovered by the shutter).
- (3) In this diagram, the ice guard has "iced up". The pilot has NOT operated the air intake control, but, the suction of the engine

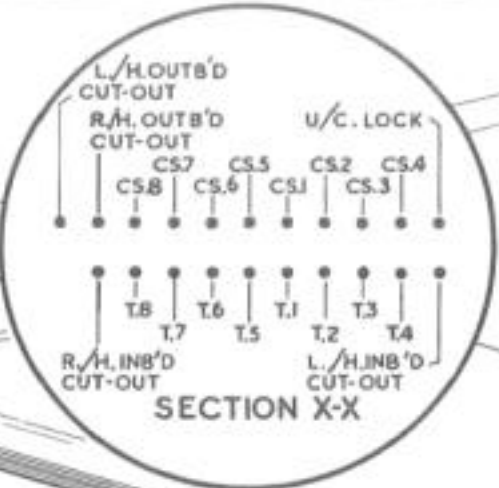
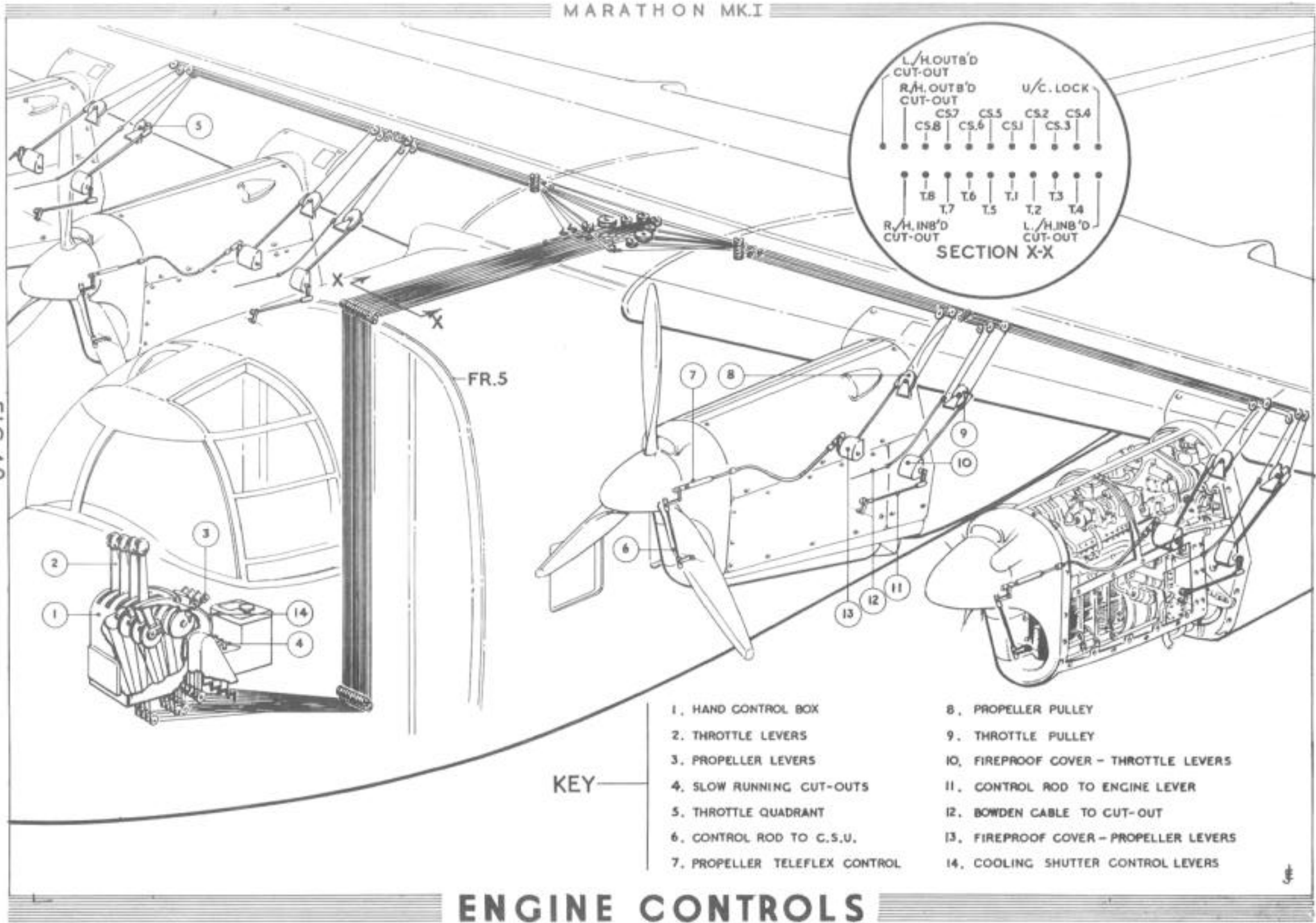

KEY

- | | |
|-------------------------------|--|
| 1. HAND CONTROL BOX | 8. PROPELLER PULLEY |
| 2. THROTTLE LEVERS | 9. THROTTLE PULLEY |
| 3. PROPELLER LEVERS | 10. FIREPROOF COVER - THROTTLE LEVERS |
| 4. SLOW RUNNING CUT-OUTS | 11. CONTROL ROD TO ENGINE LEVER |
| 5. THROTTLE QUADRANT | 12. BOWDEN CABLE TO CUT-OUT |
| 6. CONTROL ROD TO G.S.U. | 13. FIREPROOF COVER - PROPELLER LEVERS |
| 7. PROPELLER TELEFLEX CONTROL | 14. COOLING SHUTTER CONTROL LEVERS |

ENGINE CONTROLS



has caused the shutter to partially open, by virtue of the slots in the shutter operating lever and arm, against the pressure of a light spring. Air now enters as in (2).

In this type of air intake, the air is 'momentum' cleaned when entering via the 'sheltered' louvres.

KEY TO Fig. 50. AIR INTAKE ILLUSTRATION.

1. Ice Guard.
2. Slotted Connector on Ram.
3. Shutter Slotted Actuating Lever.
4. Shutter Control Arm.
5. Shutter.
6. Ram.
7. Pneumatic Pipe to Ram.
8. Sheltered Louvres.
9. Cowling Panel (incorporating air intake assembly)
at the left hand side of the Power Plant.



MARATHON. I

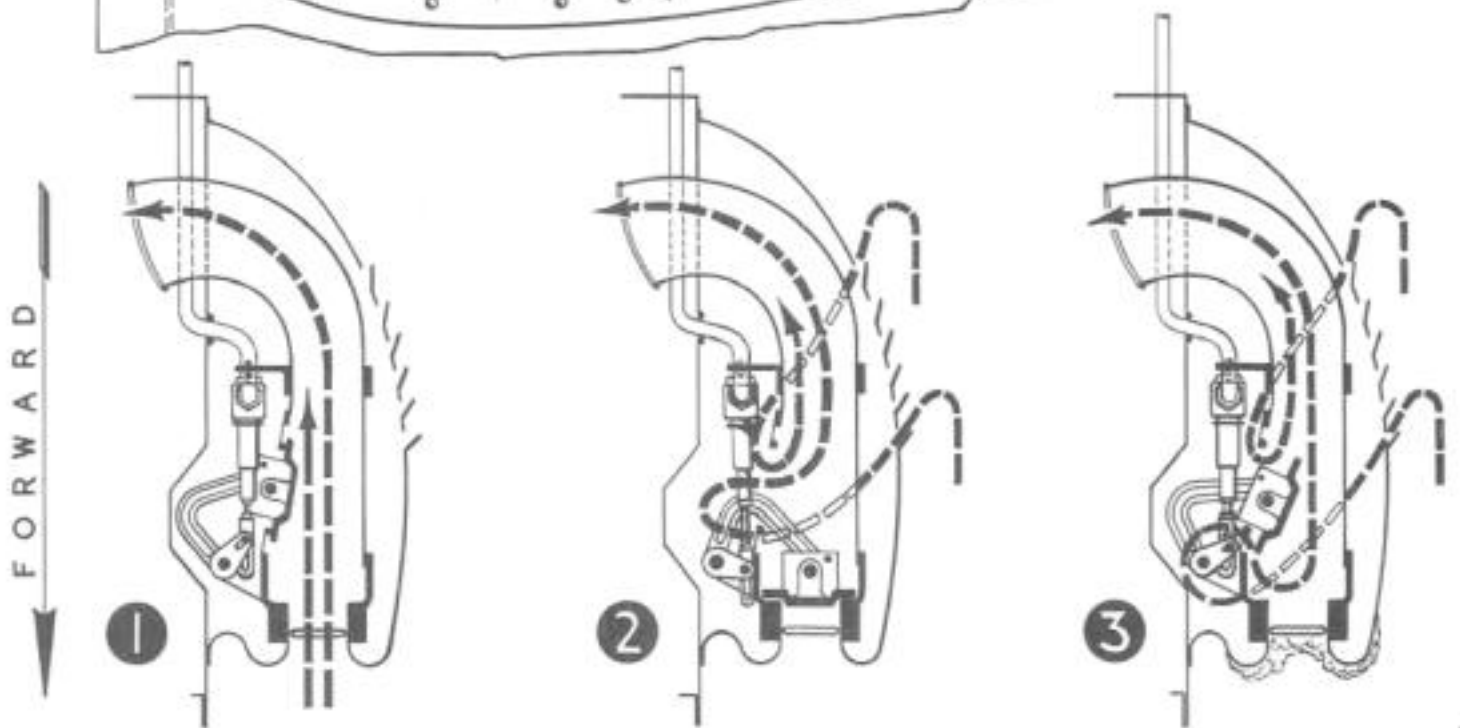
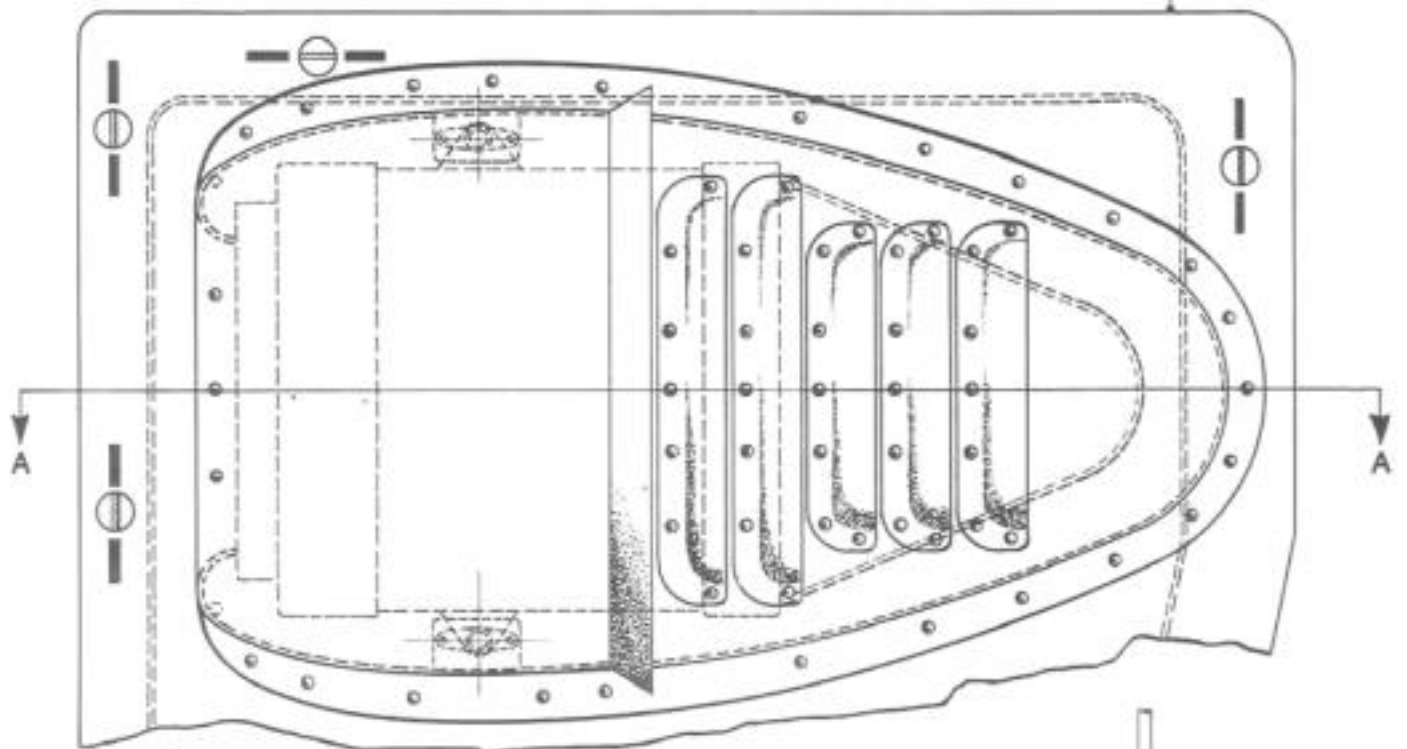
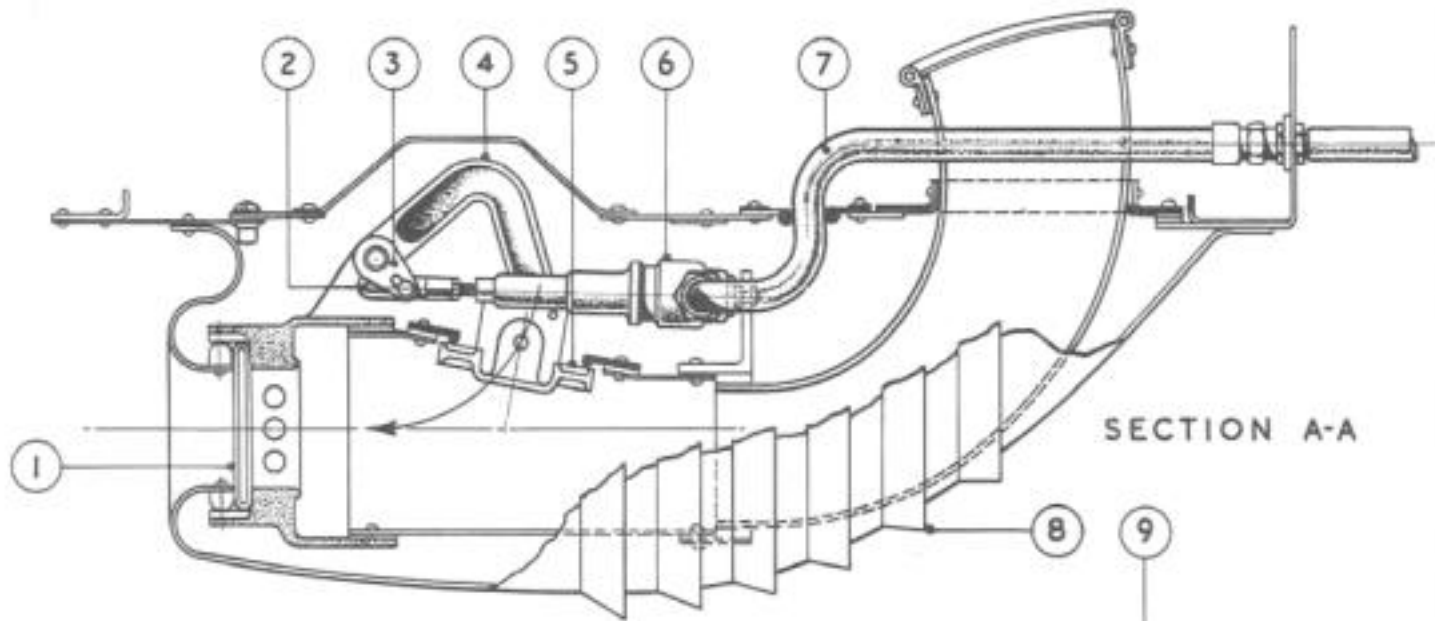

AIR INTAKE
FIG. 50



POWER PLANTS.

S E R V I C I N G .

GENERAL.

Complete and detailed information in respect of the Gipsy Queen engines is available in the "De Havilland Gipsy Queen Series 70-2, 345 H.P. Aero-engine, Operation, Maintenance and Overhaul Manual", which also gives a list of engine accessory manufacturers.

Complete and detailed information regarding engine driven accessories for aircraft services will be found in the publications given in the "List of Associated Publications" to be found at the front of this manual.

Certain information is repeated here for convenience in so far as it affects the engine or accessories.

OIL FILTERS.

Oil filters, apart from those in the engine are not utilised. The engine suction filter is situated in a small casing attached to the top right hand corner of the crankcase wall whence it can be removed for cleaning purposes by unscrewing the hexagon-headed plug above the crankcase breather. The engine pressure filter is contained in a chamber in the left hand side of the oil pump and is enclosed by a bolted on cover, through which access to it is obtained for examination and cleaning. The two scavenge filters are fitted in chambers in the lower left hand side of the rear wall just above the pressure filter unit where they are each enclosed by a dished cover attached by two studs and nuts. The filter for the constant speed unit is attached by four studs and nuts at the front underside of the crankcase, adjacent to the constant speed unit and to the front cylinder.



CONTROL SETTINGS AND ADJUSTMENTS. - see illustration No. 51.

Ensure that the inboard propeller levers are not in the braking position. (If the propeller braking mechanism is not utilised a stop will be found fitted to the hand control box to prevent the levers from being placed in the braking position).

Place the throttle levers (1) in the mid-position.

Set pulleys and quadrants (2) so that the levers and plates (3) take up the mid-position and adjust turnbuckles (4) to suit.

Move throttle levers (1) to the closed position.

Move levers (5) and (6) clockwise until lug (7) abuts stop (8).

Taking care not to alter the setting of levers (3), (5) and (6), adjust and fit control rods (9). Ensure that the aft ball-ends take up the mean position in the slots in levers and plates (3).

With the engine indicators at 'S.R', fit control rods (10) ensuring that the aft ball-ends take up the centre position in the slots in levers (6).

Move the throttle levers (1) to the open position, check the movement of levers (3), (5) and (6), and ensure that the engine indicators operate in agreement with the positions of the throttle levers.

The range of movement can be adjusted by repositioning the aft ball-ends in levers (6). Movement forward will increase the range, movement aft will decrease the range. Further adjustment can be effected by repositioning the aft ball-ends in levers and plates (3); inward to decrease, outward to increase.

Slow Running Cut-Outs.

When the control knobs are pulled upward, the slow running cut-out lever on each engine abuts a stop at the end of its travel. When the knobs are released the levers are returned to their normal position by a spring. Adjustment can be effected by the adjusters on the Bowden Cable.

Propeller Control Settings. - see illustration No. 51.

Place propeller control levers (11) in the mid-position.

Set pulleys (12) so that levers (13) take up the mid-position and adjust the turnbuckles (14) to suit.

Move levers (15) and (16) to position shown and, without disturbing the setting of these levers or of levers (13), adjust and fit control rods (17).

Position bell-cranks (18) as shown and, without altering the setting of the levers, adjust and fit the teleflex controls (19) so that the aft ball-ends take up the mean position in the slots in levers (16).

Ensure that the arrow on each constant speed unit shaft is horizontal, then fit levers (20) in position shown.

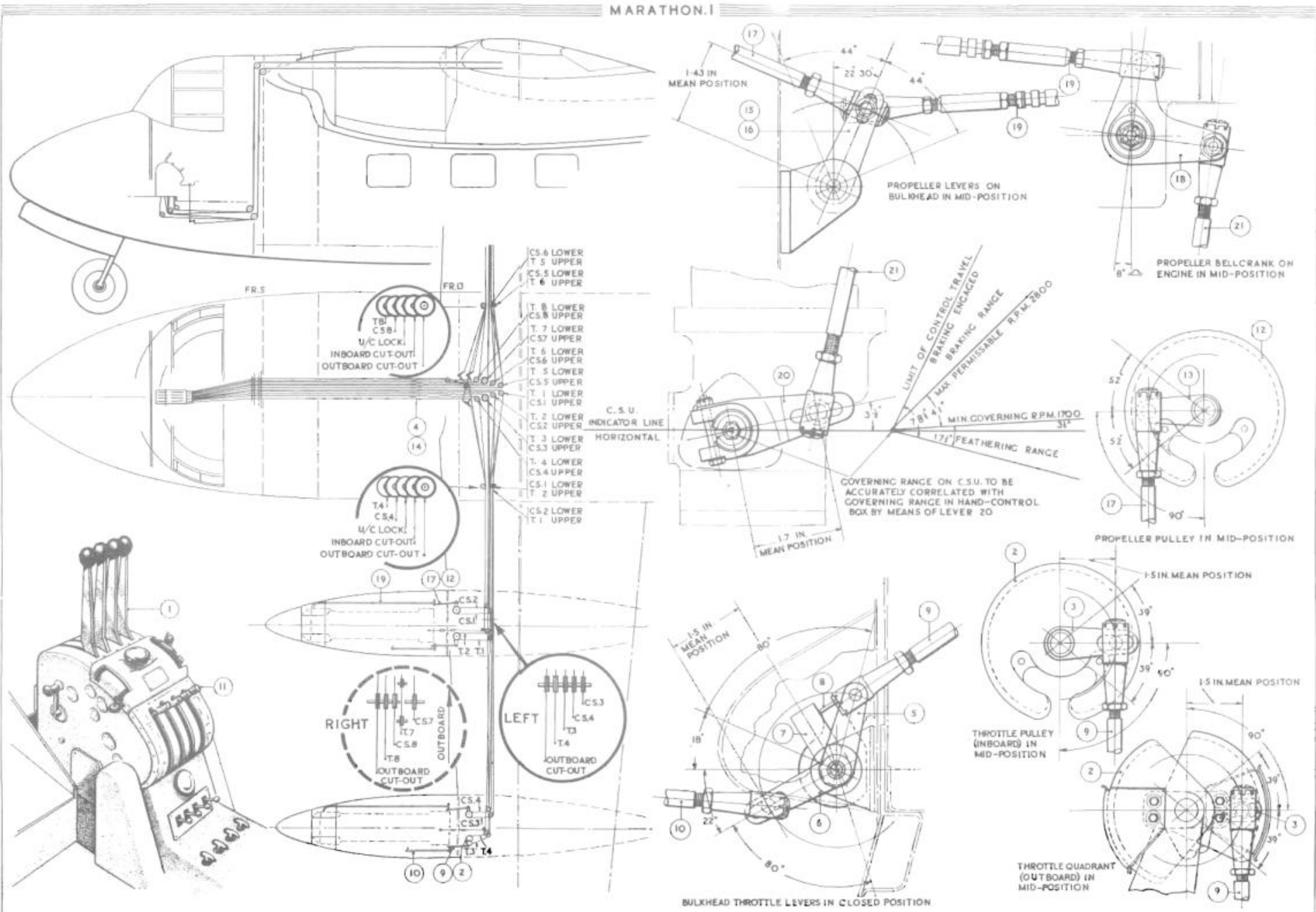

ENGINE CONTROLS
ADJUSTMENTS & SETTINGS



Without disturbing the lever settings, adjust and fit rods (21), and ensure that the lower ball-ends take up the mean position in the slots in levers (20).

Move the propeller levers (11) through their full range of travel and ensure that the movement of levers (20) is accurately correlated with levers (11). If incorrect, adjustment can be effected by:-

Adjusting the minimum r.p.m. stops in the hand control box.

Repositioning lower ball-ends in the slots in levers (20) - forward to increase the range, aft to decrease.

Repositioning forward ball-ends in slots on levers (16) - movement upward will increase the range, downward movement will decrease.

If, after carrying out the above adjustments, movement of levers (11) and (20) is still not correlated, further adjustment may be obtained by repositioning lever (20) on the C.S.U. shaft. The lever and shaft are both splined, one spline altering the setting of the lever $7\frac{1}{2}^{\circ}$. To effect this adjustment, set remaining levers as previously described then reposition lever (20), and adjust control rod (21) to suit.



POWER PLANT.

REMOVAL AND ASSEMBLY.

GENERAL.

Before attempting to remove either power plants or propellers, it is essential that the aircraft be trestled so as to avoid the possibility of the aircraft tilting backward when removal is effected. For trestling instructions see Part 2 of this manual.

It is not possible to remove an engine without first removing one side frame of the engine mounting, the nose cowling and a portion of the cowling mounting structure. It is therefore advisable to remove the power plant as a unit and to carry out subsequent operations with the plant mounted in a stand.

EQUIPMENT REQUIRED FOR POWER PLANT REMOVAL.

Jacks and Trestles.	-	See Part 2.
Power Plant Stand.	-	C.6098104.
Engine Sling.	-	-
Oil Tank Jury Rig.	-	6030066 (Left hand side). 6030067 (Right hand side).

POWER PLANT REMOVAL FROM AIRCRAFT. - See illustration No. 52.

Trestle the aircraft and chock the wheels.

Remove the propeller and spinner - see de Havilland publication No. 3.HFB.

1. Remove the engine cowling panels. This will entail removing the top rail to which the upper panels are hinged, the air intake panel, and disconnecting the air cooling shutter actuator at its lower end.



Remove the leading edge upper and side fairing panels from the rear of the bulkhead upper portion.

Disconnect the following electric cables at their multipin plug and socket connections at the fireproof bulkhead.

- | | | | |
|-----|--|---|--|
| 2. | Cooling Shutter Transmitter
R.P.M. Generator. |) | Plug "ENG. A" at the right hand
side of the bulkhead. |
| 3. | Oil Pressure Transmitter.
Oil Temperature Bulb.
Fuel Pressure Transmitter.
Kent Flowmeter (when fitted) |) | Plug "ENG B" at the right hand
side of the bulkhead. |
| 4. | Cooling Shutter Motor.
Flame Switches.
Inertia Switches. |) | Plug "ENG C" at the left hand
side of the bulkhead. |
| 5. | Engine Ignition Switch. | | At the left hand side of the bulkhead. |
| 6. | Starter and Feathering Motor. | | Plug "ENG E" at the left hand side of
the bulkhead. |
| 7. | Generator Cable.
Note. Inboard engines only
when two 1,000 watt generators
are fitted, and all engines
except the left hand outer
when three 750 watt generators
are fitted. | | Plug "ENG D" at the left hand side of
the bulkhead. |
| 8. | Thermo Couple.
Note. The pins should be short-
circuited to the bulkhead. | | At the right hand side of the bulkhead. |
| 9. | Cooling Shutter Transmitter and
Actuator Motor Cables. | | At the actuator. |
| 10. | Disconnect the starter earth connection from the left hand side of
the bulkhead. | | |
| 11. | Remove the pin connecting the out-off Bowden control cable to its
engine lever. | | |
| 12. | Disconnect the C.S.U. teleflex control from the bulkhead lever; this
is a ball-end joint and the connection is provided with a fireproof cover. | | |
| 13. | Disconnect the throttle control rod from its bulkhead lever; this also is
a ball-end joint and the connection is provided with a fireproof cover. | | |

Ensure that the fuel cocks are "OFF".

Disconnect the following pipelines at their bulkhead connections:-

14. Fuel Feed Pipe.

MARATHON I

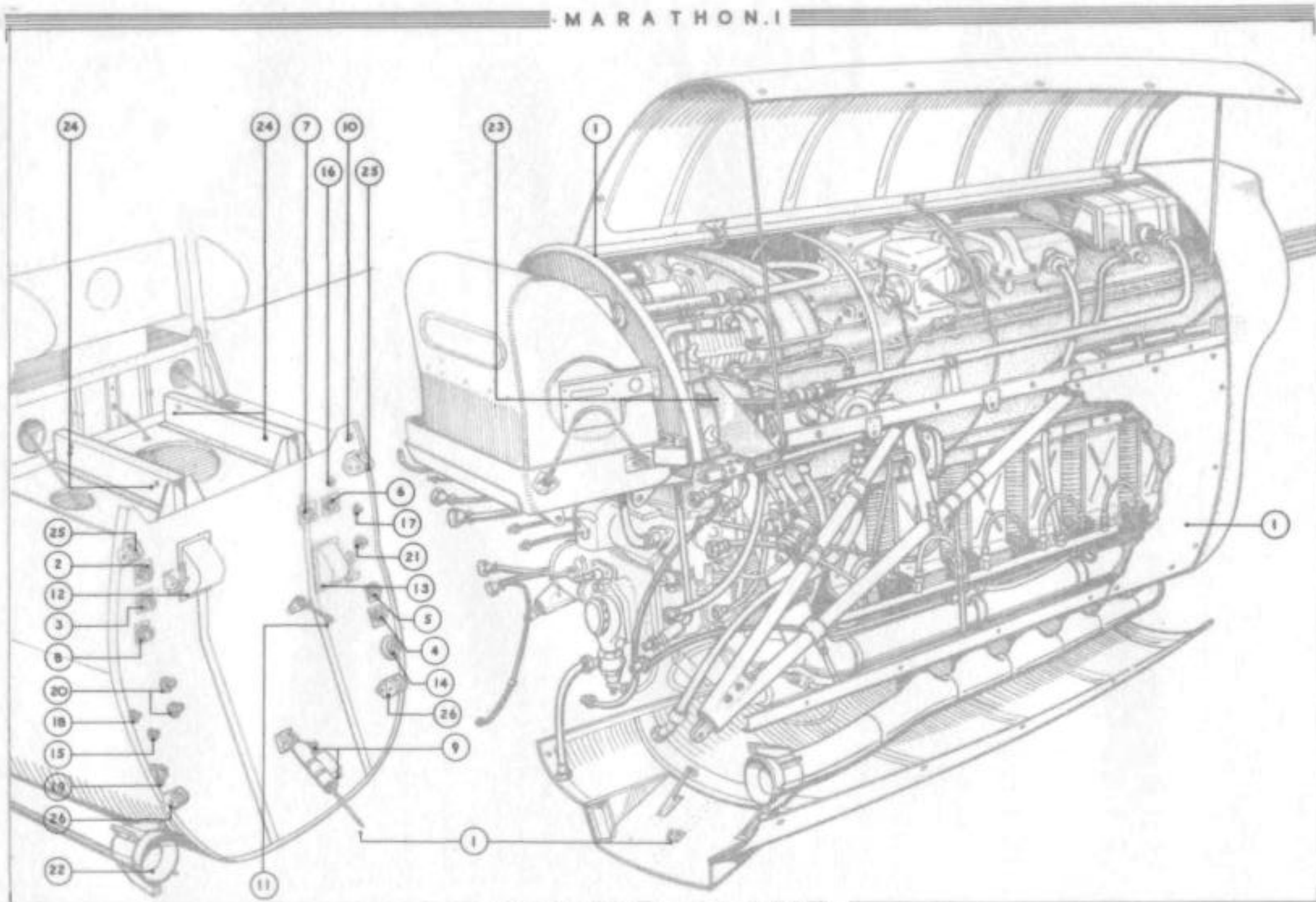

FIG. 52

88 B

POWER PLANT
R E M O V A L



15. Priming Pipe.
16. Boost Gauge Pipe.
17. Pneumatic Pipe from the Compressor - outboard power plants only.
18. Propeller De-Icing Flexible Pipe.
19. Fire Extinguisher Flexible Pipe from the six-way junction box.
20. Vacuum Feed and Exhaust Pipes - outboard power plants only.
21. Compressor Pipe.
22. Disconnect the exhaust ejector pipe at its spring loaded connection to the extension pipe and at its articulated connection to the nacelle and remove the pipe.
23. Fit the oil tank jury rig; the upper securing bolt must be removed from each end of the upper bulkhead top transverse stiffening member and the lower securing bolt from each end of the upper bulkhead lower transverse member. Use Part No. 6030066 at the left hand side of the power plant and Part No. 6030067 at the right hand side. The split, hinged tube fits around the upper member of the engine mounting while the butterfly headed screwed pins engage in the holes from which the stiffener member securing bolts have been removed. Remove the screws securing the upper portion of the bulkhead to the main bulkhead.
24. Remove the four bolts securing the oil tank cradle to the platform at the rear of the removable portion of the bulkhead.
25. Remove the bolts securing the top attachments of the engine mounting to the bulkhead fittings. The bolts are part No. 6030998, and with them are used washers A.G.S. 160/F, nuts A.16Y. J.S. and split pins; the clearance between the mounting attachments and the bulkhead fittings is taken up by shims S.4192.
26. Remove the bolts securing the bottom attachments of the engine mounting to the bulkhead fittings. The bolts, nuts and washers are identical with those used for the top attachments but shimming is effected by using shims S.2032 - S.2036.

The power plant can now be lifted clear of the airframe.

POWER PLANT ASSEMBLY TO AIRCRAFT.

Trestle the aircraft and chock the wheels.

Assemble the power plant to the airframe in the reverse order to that given for removal, noting the following points:-

The engine mountings should be so aligned that the thrust line is parallel to the aircraft centre line and horizontal, with the aircraft in flying position, a tolerance of $\pm 0^{\circ} . 20'$ is permitted. Viewed from the front,



the engine centre line should be tilted at $6^{\circ} \pm \frac{10'}{40'}$ to the vertical.

Adjustment can be effected by shims between the engine mounting attachments and the attachment brackets on the bulkhead, and between the engine mounting feet and the engine. The throttle controls, constant speed unit controls and slow-running cut-out controls should be adjusted to the settings given in the "Servicing" Section of this part of the Manual.

ENGINE AND PROPELLER CONTROLS.

This section covers the removal and assembly of the throttle, propeller and slow-running cut-out cables between the point of connection to the hand control box and the nacelles. Since the run of cables for the undercarriage emergency release and fuel systems are similar to those already quoted, the removal operations for these are also included in this section.

Two sizes of solid pin and two different types of turnbuckle have been used on the cable assemblies and the associated eye-fork-end and turnbuckle fittings are so arranged on the varying lengths of cable as to prevent incorrect assembly. The position of turnbuckles and banks of pulleys are given in illustrations Nos. 53 and 54. The illustrations also indicate the positions of individual cables on the main banks of pulleys where confusion might arise on re-assembly.

For connections to the hand control box reference should be made to Part 18, which contains the removal and assembly operations for the box.

The removal of connecting rods and Bowden cables from the engine bulkheads are considered obvious and are therefore not covered in the following text.

Removal.

When removing cables, a piece of cord should be tied to one end of the cable being removed and drawn through the pulleys as the cable is being withdrawn; by tying the replacement cable to the cord and pulling in the reverse direction, replacement of cables will be much facilitated.

The following operations are necessary for removal of the throttle, slow-running cut-out, fuel system and undercarriage emergency release systems. Before commencing operations, reference should be made to the "Panels and Covers" illustration (No. 10) for means of access to the banks of pulleys.

1. Remove the floor panels aft of the hand control box, the access panels on the front face of the bulkhead at frame 5 and the access panels in the roof between frames 5 and 15.
2. Remove the access panels on the upper and lower surfaces of the main plane and inside the nacelles.
3. Remove the bonding leads from the cables between the hand control box and frame 15.
4. Remove all guards and guard bolts from the following positions - the aft end of the hand control box, the top and bottom of frame 5, aft of frame 12 and the pulley assembly forward of frame 15.
5. Remove the fairleads from the fuselage structure where the cables pass through the skin at frames 14 and 15.
6. Remove the guards and guard bolts from the banks of pulleys at the wing roots, the inboard nacelles, and at the slow-running cut-out

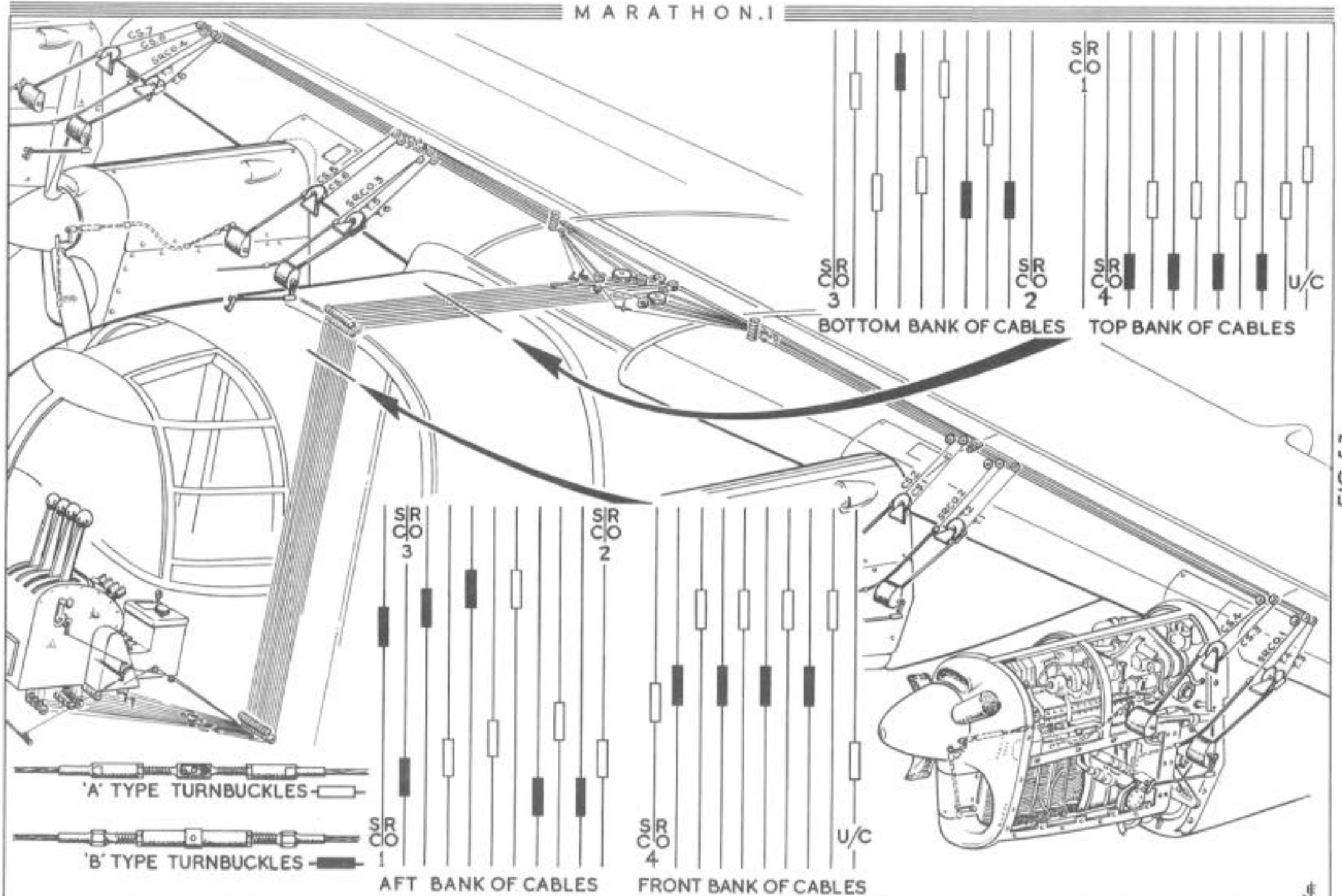
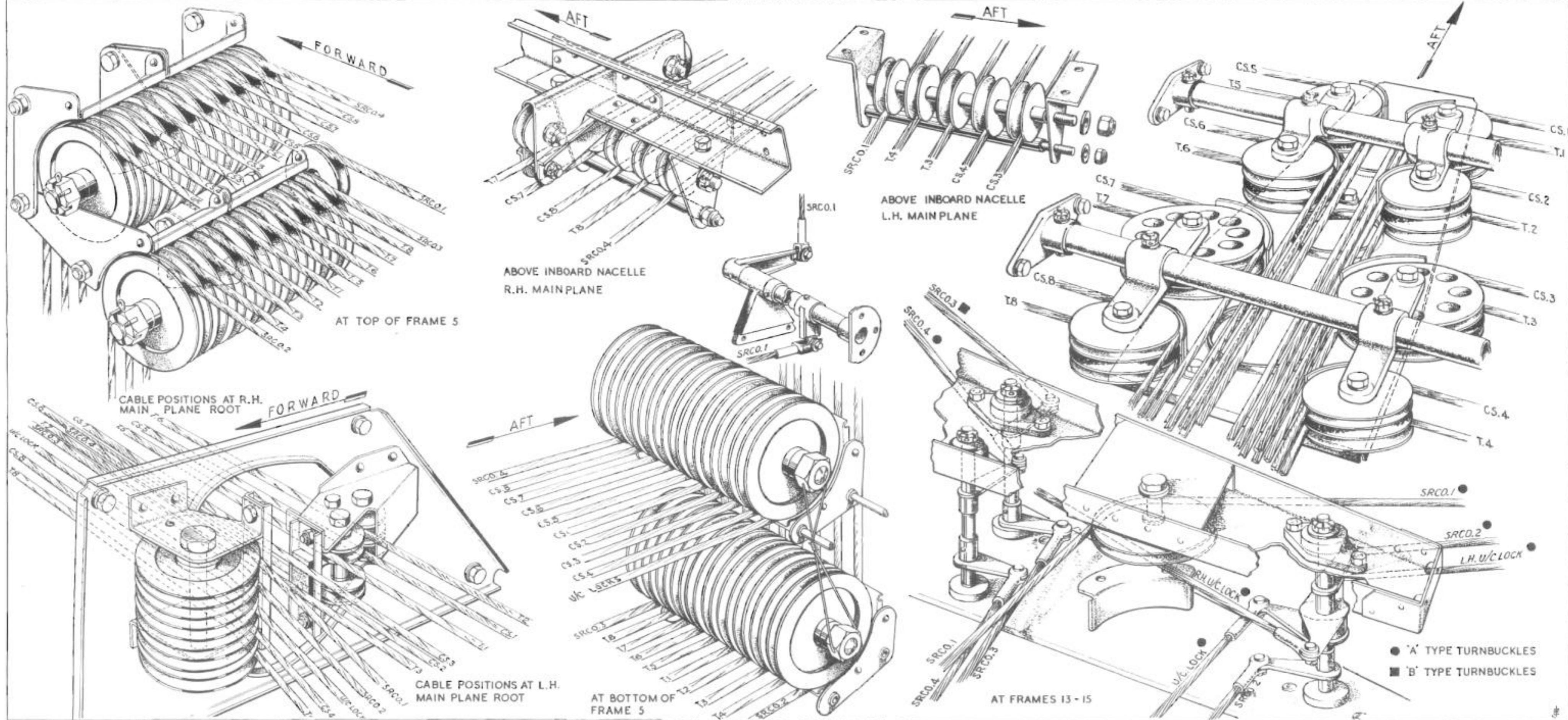

FIG-53

ENGINE CONTROLS
REMOVAL & ASSEMBLY





ENGINE CONTROLS
REMOVAL & ASSEMBLY



pulleys at each nacelle.

7. Remove the solid pins securing the propeller, throttle and slow-running out-out cables to their respective quadrants and bowden cable ends at each nacelle.
8. Tie a cord, of sufficient length to reach the fuselage, to each cable end; when the cord has been drawn through in place of the cable, secure the ends to adjacent structure. Fasten a tag to each cord and mark it with the particular cable number - the cable number will be found marked on a small brass plate clamped to each cable.
9. Gaining access through the undercarriage doors, detach the emergency release cable from the undercarriage lock lever.
10. Release the throttle, propeller and undercarriage emergency release cables from the inclined pulleys at each nacelle by withdrawing the pulleys from their brackets. Ensure that washers and distance pieces are not lost or incorrectly repositioned when replacing the pulleys with the cord, in place of the cable removed.
11. Gaining access through the access covers above the fuselage, disconnect the slow-running out-out turnbuckles and withdraw the cables.
12. Disconnect the turnbuckles on the undercarriage emergency release cables, near the lever aft of frame 13, and withdraw the cables.
13. Disconnect the short lengths of cable attached to the undercarriage emergency release lever and the three slow-running out-out levers forward of the pulley assembly at frames 13 - 15. Secure tags, carrying the cable numbers, to the levers.
14. Disconnect the throttle and propeller cable turnbuckles, fore and aft of frame 12 and withdraw the aft portions of the cables - secure the cords to adjacent structure.
15. Disconnect the turnbuckles on the forward face of the bulkhead at frame 5, withdraw the cables from the two top banks of pulleys and the pulley adjacent to the rudder cable pulleys.
16. Disconnecting the solid pin and turnbuckle connections under the hand control box, withdraw the cables from the two banks of pulleys at the bottom of frame 5 bulkhead and the two small pulleys at the aft end of the hand control box.
17. Remove the short lengths of cable connected to the lever on the right hand end of the cross-shaft adjacent to the lower banks of pulleys at frame 5 bulkhead.
18. Remove the cable connected between the left hand outboard slow-running out-out lever on the hand control box and the lever on the left hand end of the cross-shaft.
19. Disconnect the undercarriage emergency release cables from the lever in the hand control box and withdraw them. The cable passing down and forward from the undercarriage release lever is secured to a torque

MARATHON I

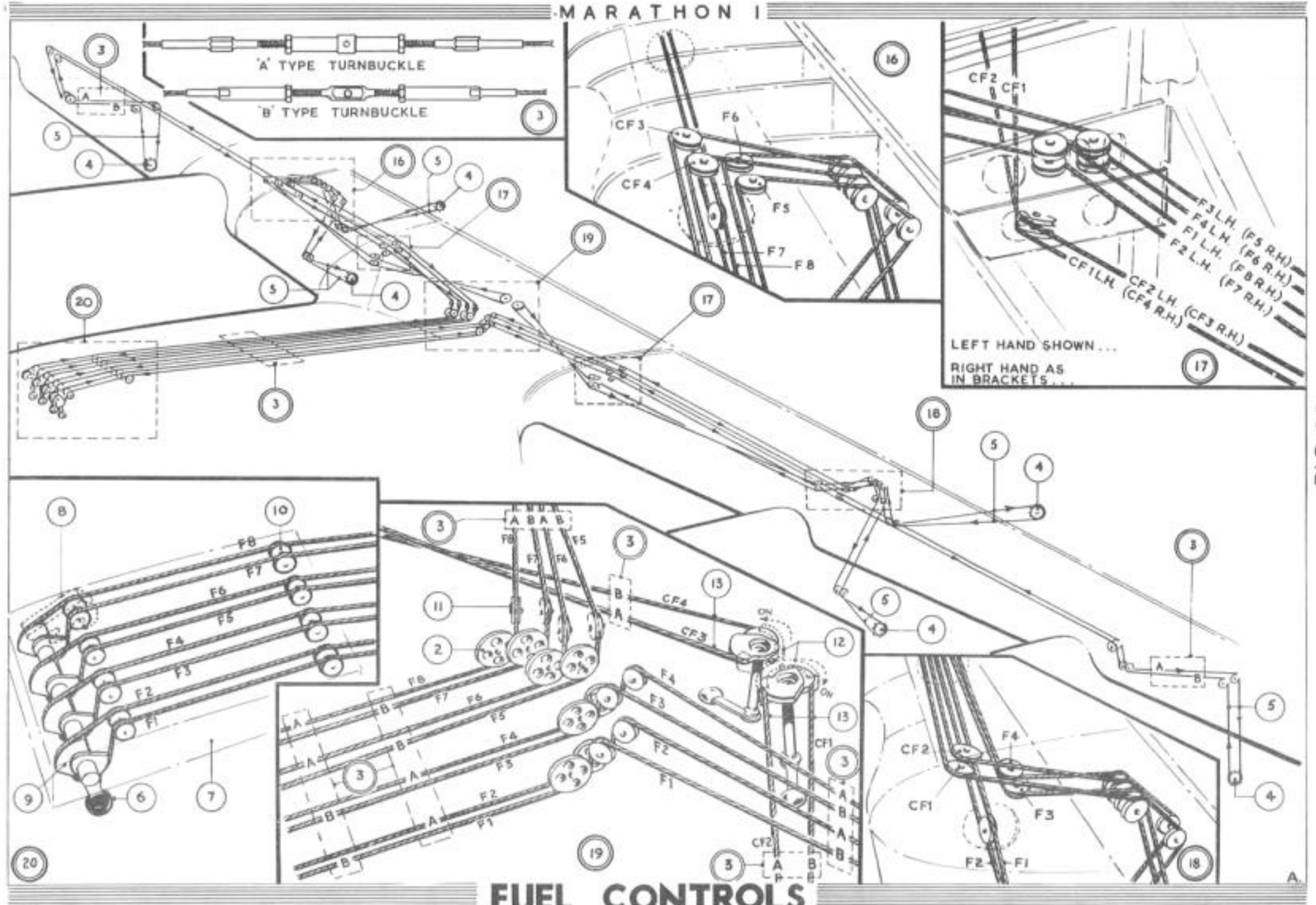

FIG. 55

FUEL CONTROLS
REMOVAL & ASSEMBLY



- shaft on the front face of the diaphragm it passes through.
20. Disconnect the slow-running out-out cables at the connection to the control lever on the engine and remove the Bowden cables from the fire-proof bulkhead and frame 2 of the nacelle.
 21. Remove the connecting rods from between the quadrants and the fire-proof bulkhead levers.

Main and Cross-Over Fuel Control Cables - See illustration No. 128.

1. Remove the access panels from the upper and lower surfaces of the main planes, from the nacelles, and from the roof of the fuselage.
2. Remove the guards from the pulleys aft of frame 12 and in the nacelles.
3. Disconnect the turnbuckles in the leading edge, above the fuselage, and at frames 6 and 8 inside the fuselage.
4. Disconnect the chains at the fuel cocks.
5. Tying a piece of cord to one end of each cable in the nacelles, withdraw the cables through the aperture in the leading edge above the fuselage. Note: It will be necessary to dismount the pulleys at positions where fixed guards are fitted. Ensure that washers and distance pieces are not lost. Fasten a tag, carrying the cable number, to each cord.
6. Remove the handles from the fuel cock levers in the roof of the crew compartment.
7. Lower the electrical control panel.
8. Remove the guards at the control levers and pulleys aft of frame 2.
9. Disconnect the cables from the lever quadrants and attach a suitable length of cord to each cable.
10. Dismount the pulleys forward of frame 4 and withdraw the cables aft.
11. Gaining access through the leading edge of the main plane, above the fuselage, temporarily remove the small pulleys from the outer skin of the fuselage and pass the cables into the fuselage.
12. Remove the guards from the cross-over control lever cable quadrants.
13. Disconnect the short lengths of cable at the control lever quadrants and withdraw the cables.

Assembly.

Assembly operations will be a reversal of the removal operations. A study of the illustrations given in this section and of the "Hand Control Box", illustration No. 114, in Part 18, along with the cable numbers on the cords which have been left in place of the lengths of cable withdrawn, will ensure correct assembly.



When fitting cables to pulleys which have to be dismantled for the operation, ensure that distance pieces, washers etc. are correctly repositioned. The screws in the handles of the levers should be centrepopped to lock them.

Fitting of bonding leads should be carried out with care to ensure that good electrical contact is obtained without damaging the cables. The cables and bonding lead claws should be thoroughly cleaned before mating. Bonding lead claws on adjacent cables should be staggered fore-and-aft, and so positioned that bonding leads are not taut at the extremes of cable travel. When the claws have been crimped to the cable, the assembly should be coated with blue, oil base paint to Spec DTD.62B as protective treatment. The bonding resistance at each point must not exceed 0.05 ohm. Control settings and cable tensions should be adjusted in accordance with instructions given in the Servicing Section of this Part.



- shaft on the front face of the diaphragm it passes through.
20. Disconnect the slow-running out-out cables at the connection to the control lever on the engine and remove the Bowden cables from the fire-proof bulkhead and frame 2 of the nacelle.
 21. Remove the connecting rods from between the quadrants and the fire-proof bulkhead levers.

Main and Cross-Over Fuel Control Cables - See illustration No. 128.

1. Remove the access panels from the upper and lower surfaces of the main planes, from the nacelles, and from the roof of the fuselage.
2. Remove the guards from the pulleys aft of frame 12 and in the nacelles.
3. Disconnect the turnbuckles in the leading edge, above the fuselage, and at frames 6 and 8 inside the fuselage.
4. Disconnect the chains at the fuel cocks.
5. Tying a piece of cord to one end of each cable in the nacelles, withdraw the cables through the aperture in the leading edge above the fuselage. Note: It will be necessary to dismount the pulleys at positions where fixed guards are fitted. Ensure that washers and distance pieces are not lost. Fasten a tag, carrying the cable number, to each cord.
6. Remove the handles from the fuel cock levers in the roof of the crew compartment.
7. Lower the electrical control panel.
8. Remove the guards at the control levers and pulleys aft of frame 2.
9. Disconnect the cables from the lever quadrants and attach a suitable length of cord to each cable.
10. Dismount the pulleys forward of frame 4 and withdraw the cables aft.
11. Gaining access through the leading edge of the main plane, above the fuselage, temporarily remove the small pulleys from the outer skin of the fuselage and pass the cables into the fuselage.
12. Remove the guards from the cross-over control lever cable quadrants.
13. Disconnect the short lengths of cable at the control lever quadrants and withdraw the cables.

Assembly.

Assembly operations will be a reversal of the removal operations. A study of the illustrations given in this section and of the "Hand Control Box", illustration No. 114, in Part 18, along with the cable numbers on the cords which have been left in place of the lengths of cable withdrawn, will ensure correct assembly.



When fitting cables to pulleys which have to be dismantled for the operation, ensure that distance pieces, washers etc. are correctly repositioned. The screws in the handles of the levers should be centrepopped to lock them.

Fitting of bonding leads should be carried out with care to ensure that good electrical contact is obtained without damaging the cables. The cables and bonding lead claws should be thoroughly cleaned before mating. Bonding lead claws on adjacent cables should be staggered fore-and-aft, and so positioned that bonding leads are not taut at the extremes of cable travel. When the claws have been crimped to the cable, the assembly should be coated with blue, oil base paint to Spec DTD.62B as protective treatment. The bonding resistance at each point must not exceed 0.05 ohm. Control settings and cable tensions should be adjusted in accordance with instructions given in the Servicing Section of this Part.