

Unlimited Class Air Racing in the 1940's

A History of People and Technology

Presented by SARH Members

Tim Weinschenker

&

Joe Stamm

Air racing history in the United States – Major eras

- **1920-1928 – Major Trophy Races and the Birth of the National Air Races**
- **1929-1939 – The “Golden Age” of Air racing**
- **1946-1949 – Post War revival – The end of the Beginning**
- **1950-1960 – The “Lost Era” – No National Air Races, Regional racing only**
- **1964-1975 – The Phoenix Rises – The National Air races are reborn in Nevada**
- **1976 -1980 – Political Turmoil – NAA, PRPA, NAG, USARA, RARA – who’s really in charge???**
- **1981 – 1992 – “The Golden Years” of the modern era.**
- **1993 – Present – Flashes of brilliance**

Some misconceptions about Air Racing

- **It is about competition but except for a very brief period the sport of Air racing has not been about being on the cutting edge of Aviation technology.**
- **The sport of Air racing has been driven more by dynamic individuals with strong personalities.**
- **The most successful, long standing air racing events were the results of a very large degree of community involvement.**
- **It was the involvement of key civic leaders in the city of Cleveland and the state of Ohio that brought about the success of the National Air Races in Cleveland, Ohio.**
- **It was this same pattern that was followed when Bill Stead orchestrated the revival of the National Air Races in Reno, Nevada in 1964.**

Air Racing in the 1920's

- **The only time that Air Racing was a major, driving force that resulted in advancing aviation technology.**
- **The Pulitzer Trophy races were the vehicle for this to happen.**
- **The Pulitzer Brothers created these races to bring the United States back into the lead of aviation technology.**
- **There was a great deal of prestige for the cities that were to host these events.**
- **Because of this the event moved from City to City.**
- **It was the only era in Air Racing that involved significant funding of participants by the Federal Government.**

Technological advances from this era –

- **Wet sleeve design for liquid cooled engines.**
- **Major advancement in liquid cooled engine design.**
- **Major advancements in radiator technology.**
- **Major advancements in propeller technology.**

The Pulitzer Trophy races 1919-25

- Started out as a Cross-country race – 1919 only.
- 1920 – Roosevelt Field, New York
- 1921 – Omaha, Nebraska
- 1922 – Detroit, Michigan – First time the term “National Air Races” was used. Birth of the National Aeronautics Association (NAA) as the sanctioning body.
- 1923 – Robertson, Missouri
- 1924- Dayton, Ohio
- 1925 – Mitchel Field, Long Island, New York

Significant Aircraft of the Pulitzer era



**Curtiss CR-1 –
Winner 1921 Pulitzer Trophy Race**

Significant Aircraft of the Pulitzer era



Curtiss R3C-1

1925 Pulitzer Trophy Race Winner

Significant Aircraft of the Pulitzer era



Verville Sperry R-3

Winner of the 1924 Pulitzer Trophy Race

Significant Technology of the Pulitzer Era

Dry Sleeve cylinder cooling

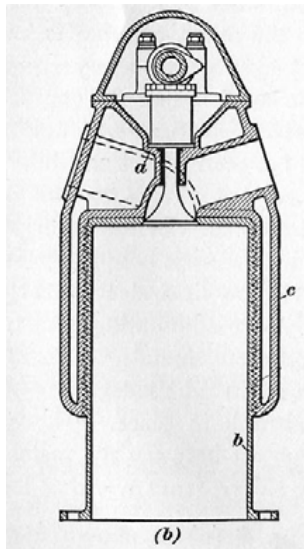

Wet Sleeve Cylinder cooling

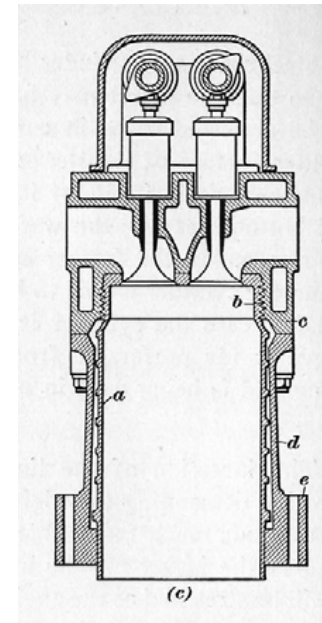

Significant Technology of the Pulitzer era

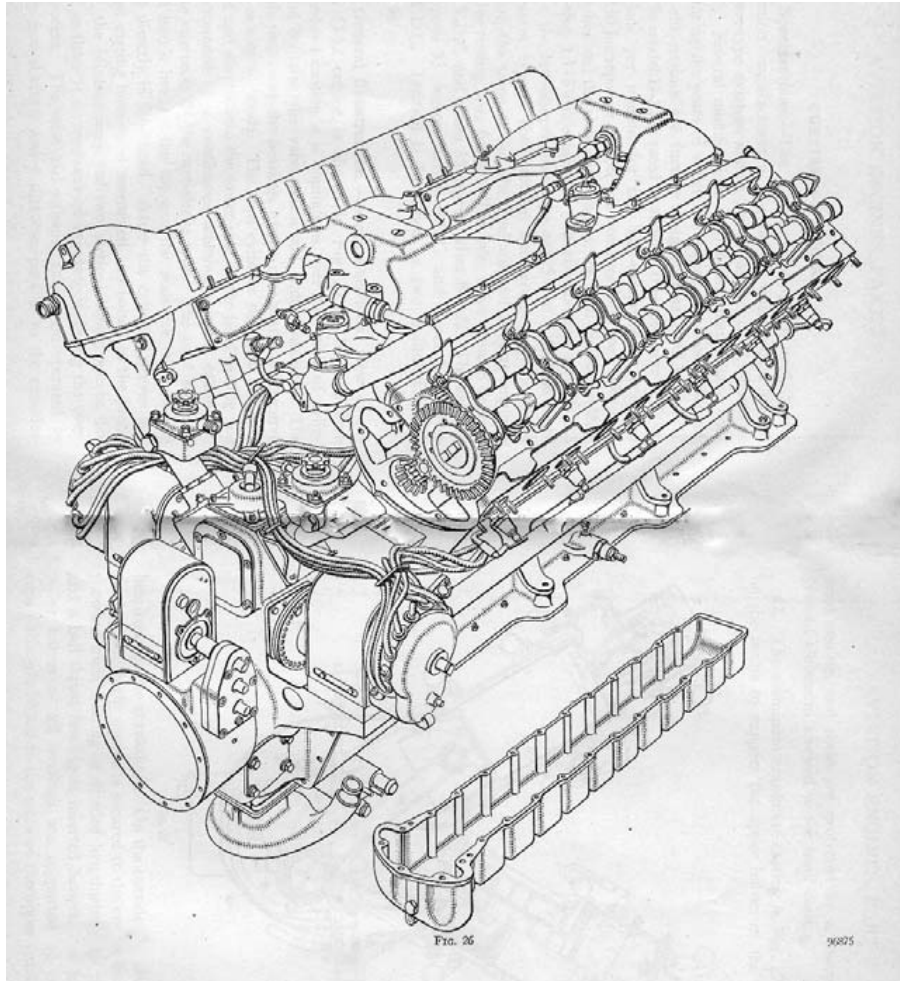

The Curtiss D-12 Engine

Significant Technology of the Pulitzer Era

1921 - Lamblin Radiator Pots

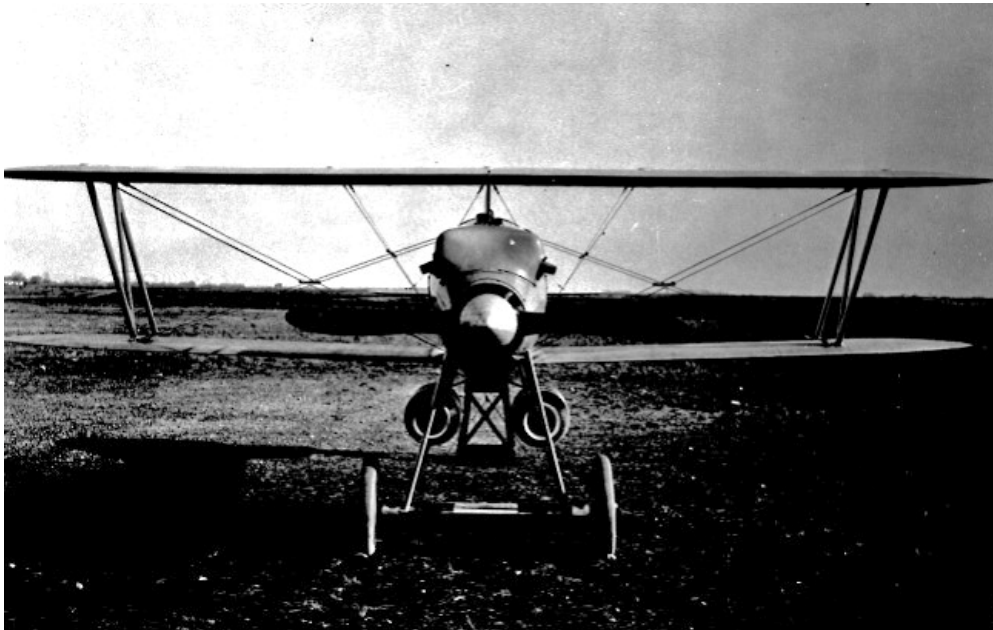

1922 – Surface radiator in wings



Surface Radiator Technology

After the Pulitzer Trophy races –

- ***National air races continued to be conducted in different locations.***
- ***They were still supported by the Military.***
- ***Technological lead was lost to Europe again as they continued to advance technology through the Schneider Trophy races.***

Air Racing from 1926 to 1928 – 1926 Philadelphia, Pennsylvania



Boeing FB-3

Air Racing from 1926 to 1928 – 1927 Spokane, Washington



Curtiss P-6 Hawk

Air Racing from 1926 to 1928 – 1928 Los Angeles, California



Boeing XF4B-1

1929 was a significant year in the history of Air racing -

- **For the first time the military aircraft entered were defeated by a civilian entrant – The Travel Air Mystery Ship.**
- **It was the first year that the Thompson Trophy was awarded to the winner of Final Race.**
- **It was the start of the tradition to hold the event on Labor Day weekend.**
- **For the first time the event was held in the City of Cleveland, Ohio.**
- **It was the beginning of the “Golden Age” of Air Racing.**

“The Golden Age of Air Racing”

- **1929-1939**
- **Driven more by personalities than technology.**
- **The City of Cleveland is considered the “home” of the Golden Age but races were conducted in Chicago and Los Angeles in addition to Cleveland.**
- **1930 would be the last time that a plane would be entered by the Military in the National Air Races until after the end of World War II.**

The “Personalities” of the “Golden Age”

Fred Crawford – The man behind the scenes



The “Personalities” of the “Golden Age”

Art Chester – The great organizer



The “Personalities” of the “Golden Age”

Steve Wittman – The practical innovator



The “Personalities” of the “Golden Age”

Benny Howard – Dammed Good airplanes



The “Personalities” of the “Golden Age”

Harold Neuman – Where did he come from?



The “Personalities” of the “Golden Age”

Rudy Kling – Low time pilot, instant glory



The “Personalities” of the “Golden Age”

Earl Ortman – Forever in 2nd place



The “Personalities” of the “Golden Age”

Jimmy Doolittle – Luckiest man alive



The “Personalities” of the “Golden Age”

Roscoe Turner – The great promoter



Aircraft of the “Golden Age”

Travel Air Mystery Ship



Aircraft of the “Golden Age”

Laird Solution



Aircraft of the “Golden Age”

Wedell Williams – Jimmy Weddell



Aircraft of the “Golden Age”

Wedell Williams – Roscoe Turner



Aircraft of the “Golden Age” Howard DGA-6 – “Mister Mulligan”



Aircraft of the “Golden Age”

Folkerts SK-2 – “Toots”



Aircraft of the “Golden Age”

Folkerts SK-3 – “Pride of Lemont”



Aircraft of the “Golden Age”

Steve Wittman – “Bonzo”



Aircraft of the “Golden Age”

Earl Ortman – “Marcoux Bromberg”



Aircraft of the “Golden Age”

Art Chester – “Goon”



Aircraft of the “Golden Age”

Keith Rider – “Firecracker”



Aircraft of the “Golden Age”

Roscoe Turner – “Laird Turner Meteor”



Aircraft of the “Golden Age”

Gee Bee – Model “Z”

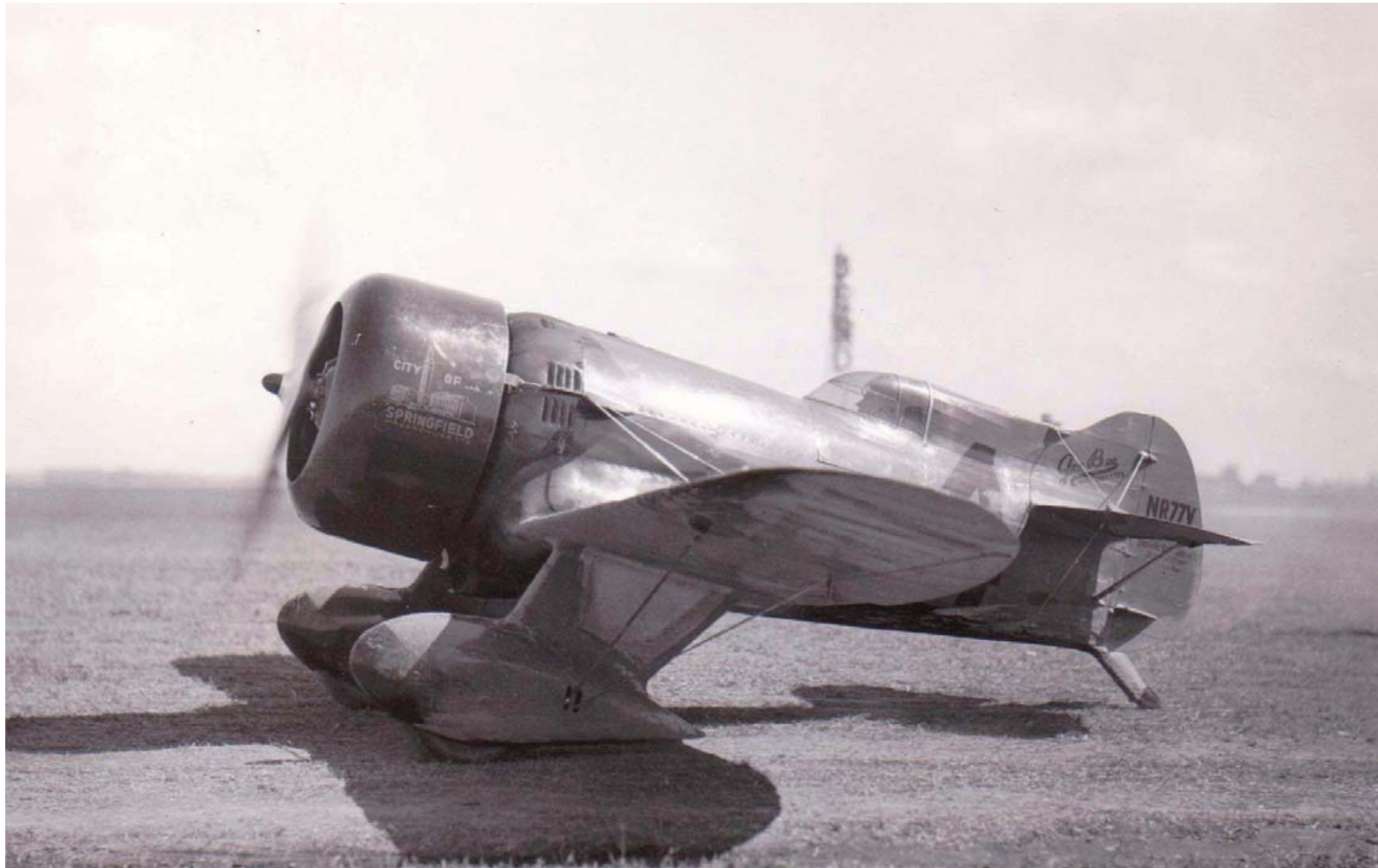

Aircraft of the “Golden Age”

Gee Bee – Model “R-1”



The Technology of the “Golden Age”

- ***Not cutting edge.***
- ***Some aircraft professionally engineered.***
- ***Some aircraft were “homebuilt”.***
- ***Some aircraft were a combination of “homebuilt” and “professional”.***

- **World War II would change the face of the World and of course aviation technology and the sport of Air racing.**

In early 1946 the civic leaders of the City of Cleveland promoted “National Aviation Day”. It would be a springboard to resumption of the Labor day Classic Thompson Trophy Races.



- **Advances in Aviation technology meant that homebuilt aircraft would not participate in the Thompson Trophy race.**
- **The advances in technology meant that there would be two Divisions of the Thompson Trophy.**
- **The “R” Division for piston engine aircraft.**
- **The “J” Division for jet powered aircraft.**
- **The “J” Division would belong to the Military.**

The Thompson “J” Trophy



- **The “R” Division was the “new” Unlimited class that would be the focal point of the weekend.**
- **It was expected that the “homebuilt” aircraft of the 1930’s would disappear to be replaced by surplus fighter aircraft.**

**This didn't stop Steve Wittman from considering a
"homebuilt" aircraft for the 1946 Cleveland Air Races....**

...but in the end he flew this P-63 Kingcobra



- **Anticipation was high when racing resumed in September 1946. What would the changes bring to the Labor Day classic at Cleveland??**
- **Would there be highly modified airplanes or simply stock fighter planes that many considered were already race planes.**

The 1946 Thompson Trophy race would turn into the “Battle of the Test Pilots”

**Representing Lockheed would be pre-war Thompson Trophy pilot and current
Chief Test Pilot Tony LeVier.**

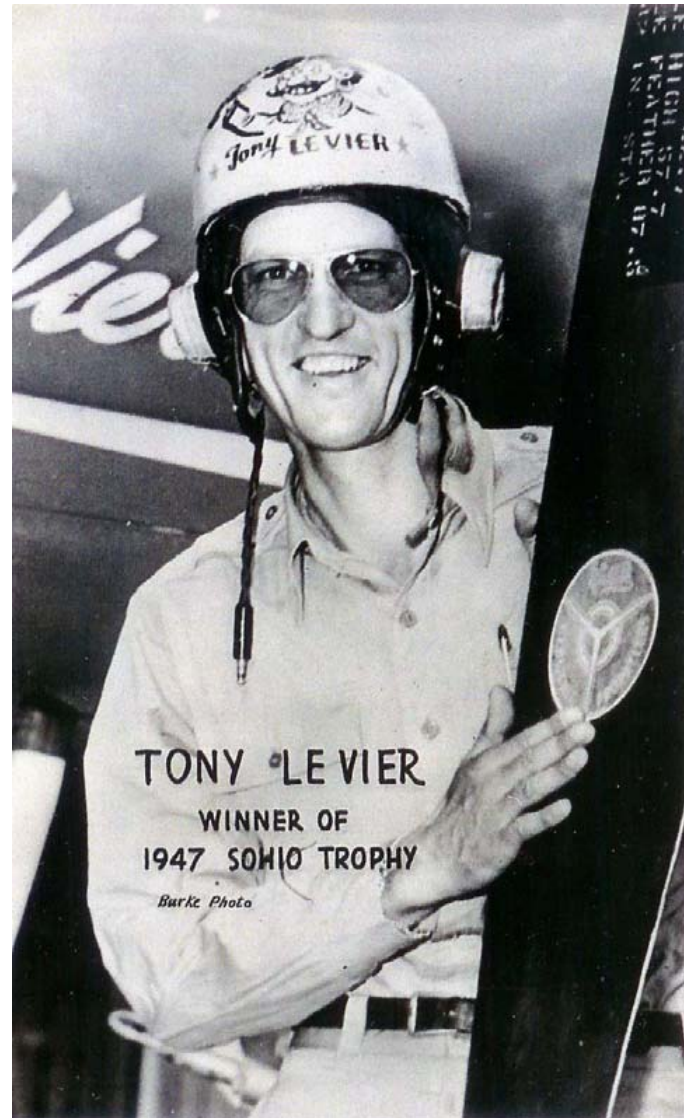

would represent Lockheed in a beautifully prepared, brilliant red P-38 Lightning



North American would be represented by their chief test Pilot George “Wheaties” Welch.



He would be flying what appeared to be a somewhat shabby looking P-51 Mustang that looked very stock in appearance.



- **Northrop test pilot Chuck Tucker would enter P-63 Kingcobras in both the cross-country Bendix race and the Thompson Trophy race.**
- **Chuck asked Max Stanley for advice on how to make the Kingcobra faster. He said clip the wings.**
- **How much asked Chuck??**
- **When you get to the landing gear you've gone too far said Max!**

Taking Stanley's advice maybe a little too literally Chuck clipped his wings maybe a little too far! This image of his P-63 personifies the image of Postwar Cleveland Unlimited class racing more than any other.



Bell Aircraft would be represented by two of its pilots with a third as a backup.

- **Chief Test pilot Jack Woolams, Tex Johnston and Chalmers “Slick” Goodlin formed “Skylanes Unlimited” to prepare two P-39 Aircobras for the Thompson Trophy.**



Cobra I” and “Cobra II” were really the class of the field in 1946.



The Thompson Trophy Race

A Technical Appreciation

Over time the technical challenge that the Thompson Trophy race presented has been lost to many of those who follow the sport of air racing.

Many have downplayed the achievements of the post war Cleveland Races in comparison to the recent history in Nevada.

It is just what makes the Thompson Trophy race a more difficult challenge in modern technology.

The Thompson Trophy Race

A Technical Appreciation

- **The first challenge is the length of the race. For 1946 the race distance was 300 miles.**
- **This translated to a race that would last from 45 minutes to an hour.**
- **This is in comparison to a Gold Race at Reno that is 8 to 12 laps in length.**
- **This meant that sustained high power for the length of the entire Thompson Trophy race was much harder to achieve just because of the sheer volume of fuel and ADI solution required to do this.**

The Thompson Trophy Race

A Technical Appreciation

- **The density altitude of Cleveland's Hopkins Airport and the Stead Facility at Reno are very different –**
- **Hopkins Airport elevation is near sea level – 792'**
- **Reno Municipal Airport elevation is 4,412'**
- **The lower density altitude required a different technical solution to produce the horsepower necessary for victory.**

The Thompson Trophy Race

A Technical Appreciation

- **The race course used for the Thompson Trophy was much longer in comparison to Reno.**
- **In 1946 though it was a rectangular course that was 30 miles in length.**
- **In 1947 the length was changed to 15 miles.**
- **In 1949 the shape of course was altered from a rectangular course to a more oval shaped course.**

1947-48 Unlimited Race Course

Approximately 15 miles in length.

Rectangular shaped.

For 1946-48 the race distance was approximately 300 miles.

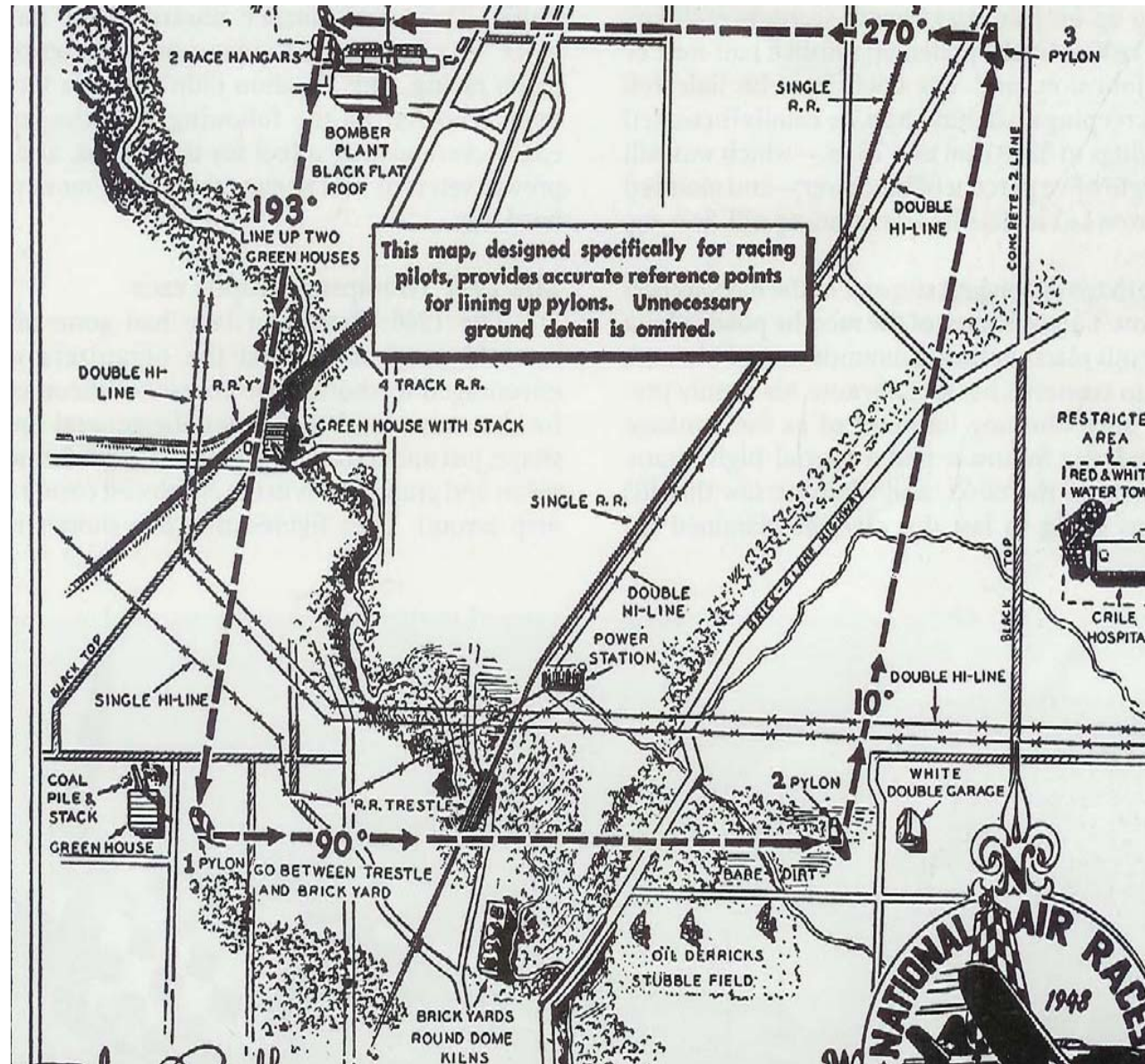

1949 Unlimited Race Course

Still approximately 15
miles in length.

Now oval shaped to lessen
the g-loading while making
turns.

For 1949 the race distance
was shortened to 225
miles.

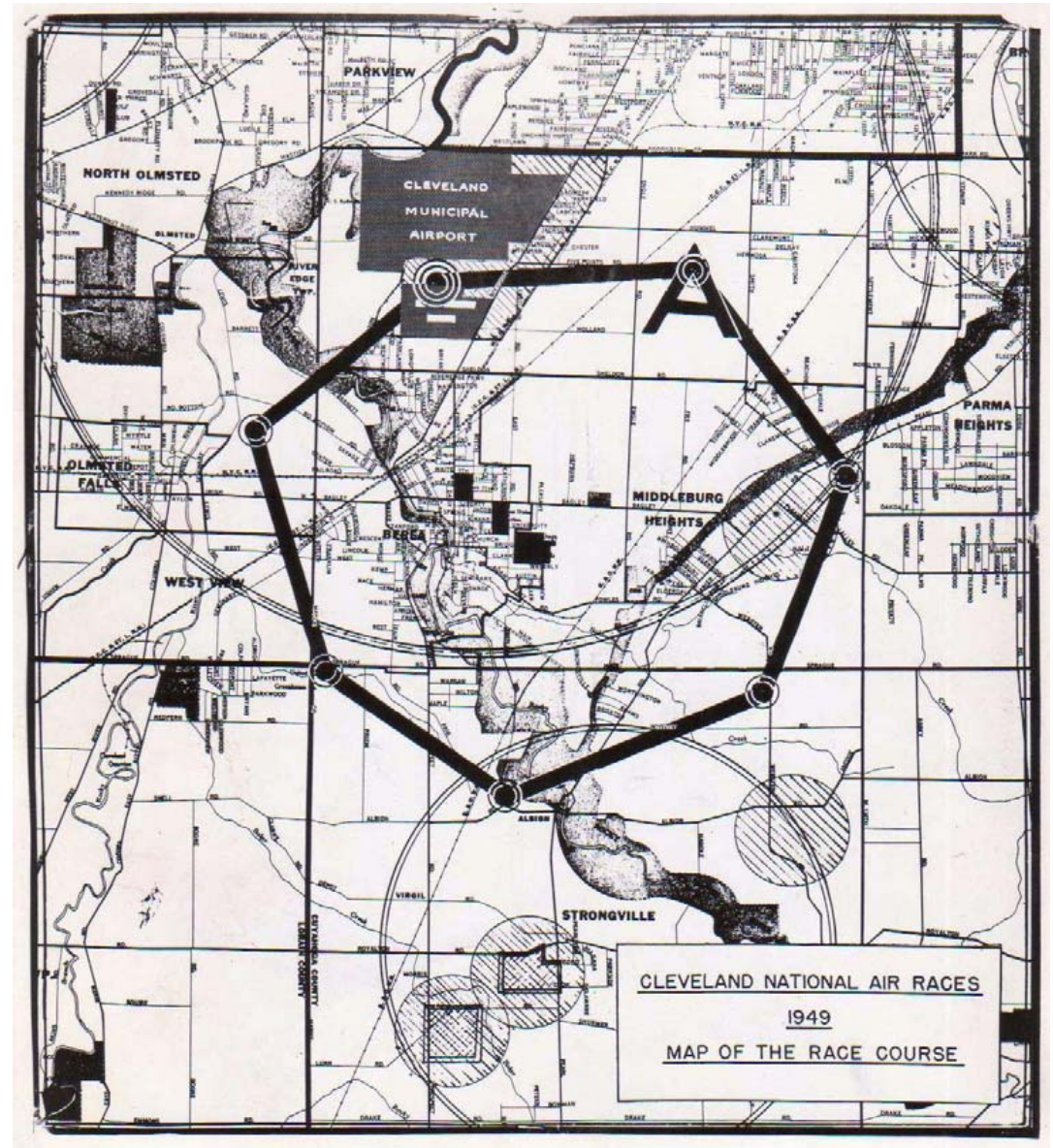

The Thompson Trophy Race

A Technical Appreciation

To sum it up the post war Thompson Trophy was a long, brutal event that provided significant physical and technical challenges for those wanting to achieve victory.

The Thompson Trophy Race

A Technical Appreciation

- **1946 was interesting because no one really knew what to expect.**
- **Surplus fighters were relatively cheap. The result was a high number of entries in both the Thompson and Bendix Trophy events.**
- **Reality of what it would take to achieve victory had not yet set in.**
- **Pre-race publicity featured pilots such as Chuck Tucker boldly predicted race speeds in excess of 500 MPH!**

The 1946 Thompson Trophy Race

The Results

- **As we now know the story of the 1946 Thompson Trophy was the astounding performance of Tex Johnston and “Cobra II”.**
- **The victory was both triumphant and tragic as “Cobra I” crashed with fatal results for Jack Woolams after he had returned to Buffalo for an engine change after qualifying.**
- **Johnston’s winning speed of 373 MPH was of course a new record.**
- **The big surprise was Tony LeVier being able to fly his P-38 Lightning to 2nd place behind “Cobra II” with an average speed of 370 MPH.**
- **Earl Ortman had also well represented the pre-war brigade with a 3rd place finish in “Sep Migton’s Mustang with a 367 MPH average.**
- **Fourth place went to a stock Mustang flown by Bruce Raymond. Named “The Galloping Ghost”, no one at the time could know just how much this aircraft would feature in the history of air racing.**

The 1946 Thompson Trophy Race

The Results

- **It had been a liquid cooled engine parade. Round engines were only represented by the relatively stock FG-1D Corsair of Navy War Hero Cook Cleland. He finished far behind the winning P-39 Airacobra.**
- **Both Chuck Tucker and George Welch were forced to retire from the race.**
- **Welch's Mustang was the victim of engine trouble.**
- **Tucker was the victim of his clipping the wings too far! The substantial clip had cut into the fuel tank.**
- **Gasoline from the leaking fuel tank had washed the grease from the gear retraction mechanism and his landing gear would not retract.**

Tex Johnston and Cobra II and the spoils of victory.



Tex Johnston and Cobra II and the spoils of victory.

