

# GETTING FROM HERE TO THERE (AND BACK)

The Range Extension Problem, 1939-1959\*

**George W. Cully**  
**AeroHistory Research &  
Reference Services**  
**Montgomery, Alabama**  
**Warty@knology.net**

# AVIATION IN 1939 – A SITREP

**The 1930s saw huge improvements in aircraft performance because of multiple advances ‘across the board’ in aviation technology:**

- Streamlining to Reduce Aerodynamic Drag**
- Light-Weight, All-Metal Construction**
- More Efficient Engines & High-Octane Fuels**
- Radios, Auto-Pilots & Navigation Aids**

# AVIATION IN 1939 – A SITREP

## Performance Statistics Reflected Those Advances:

- Between 1931 and 1939, the World's Absolute Speed Record increased from 407 mph to 469 mph.
- Between 1934 and 1939, the average speed reached to win the Bendix Trophy – for flying between Burbank, CA and Cleveland, OH (2,043 miles) – improved by almost 25%.
- Wiley Post went around the world in 187 hours in 1933; Howard Hughes did it in 91 hours in 1938.

# AVIATION IN 1939 – A SITREP

- The 1934 MacRobertson International Air Race—an 11,300 mile course between Mildenhall, England and Melbourne, Australia—was won in 71 hours by a British-built DeHavilland DH.88.
  - Second Place (90 hours): a Douglas DC-2
  - Third Place (93 hours): a Boeing 247

**The Difference between  
1<sup>st</sup>, 2<sup>nd</sup> and 3<sup>rd</sup> Place?**

# AVIATION IN 1939 – A SITREP

**The DH.88 was specially built for the race.**



**The Douglas DC-2 and the Boeing 247 were both..**

# Aviation in 1939 – A SITREP



**COMMERCIAL AIRLINERS**

# AVIATION IN 1939 – THE ISSUE

**Conclusion: The aircraft of the late 1930s were becoming increasingly fast.**

**But...the issue wasn't speed.**

**The issue was... RANGE vs. PAYLOAD**

# A LITTLE BACKGROUND

**The necessary trade-offs between Range, Payload and Speed have been pondered since the very beginnings of aeronautical science.**

**Sir George Cayley (1773-1857) recognized the issue. At least, theoretically...**





# A LITTLE BACKGROUND

**The necessary trade-offs between Range, Payload and Speed have been pondered since the very beginnings of aeronautical science.**

**Sir George Cayley (1773-1857) recognized the issue. At least, theoretically...**

**his servants did all of the empirical stuff.**



# A LITTLE BACKGROUND

The French aviation pioneer Louis Breguet (1880-1955) devised a series of mathematical statements—the Breguet Equations—for calculating Range based upon Speed, weight and fuel consumption.

It follows that the range is obtained from the following definite integral:

$$R = \int_{t_1}^{t_2} V dt = \int_{W_1}^{W_2} -\frac{V}{F} dW = \int_{W_2}^{W_1} \frac{V}{F} dW$$



# A LITTLE BACKGROUND

Put in its simplest form, the trade-off between Range and Payload can be shown graphically with an 'elbow chart.'

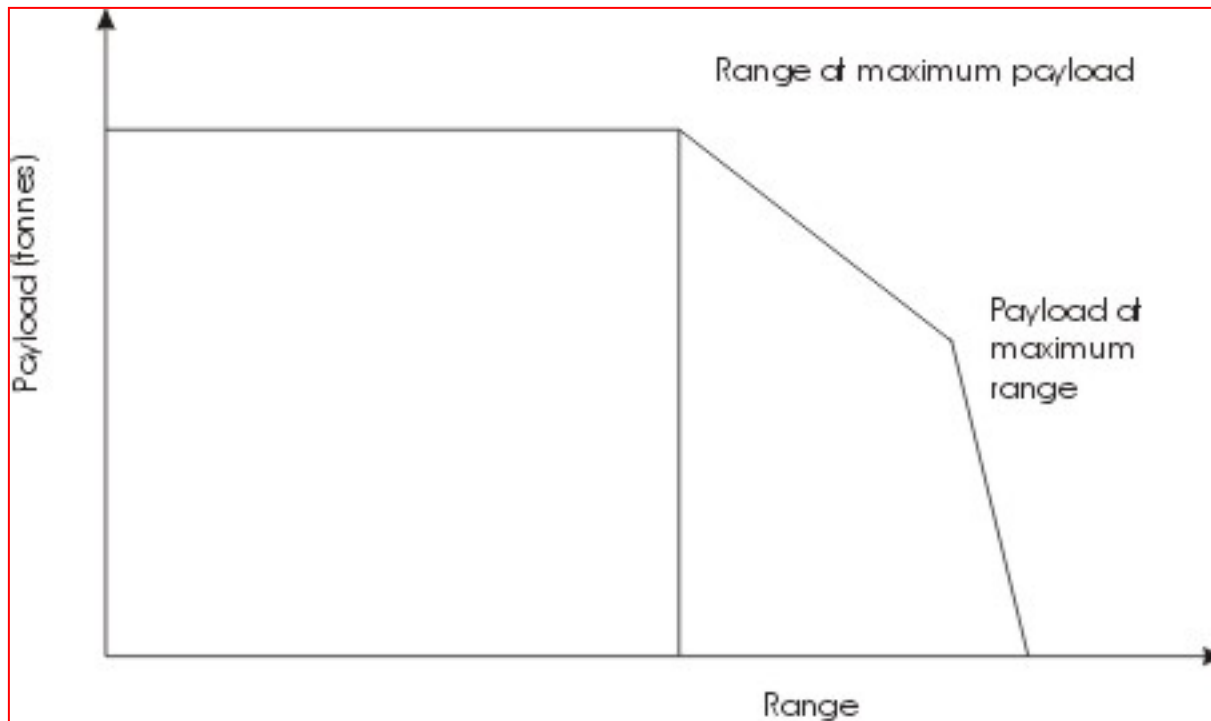

# MEANWHILE, BACK IN 1939...

The Air Corps Tactical School was the chief source of the Air Corps' doctrine in the 1930s; ACTS' chief doctrinal product was a theory called "Strategic Bombardment."



# FIGHT WITH WHAT YOU HAVE

**The ACTS' "Strategic Bombardment Theory" required bombers that were large enough to:**

- Fight their way deep into the enemy's heartland without fighter escort.**
- Accurately deliver a bomb load heavy enough to be militarily effective.**
- Fly high enough to avoid most of the enemy's artillery fire.**

# FIGHT WITH WHAT YOU HAVE

Put another way, to the Air Corps the trade-off was seen as a challenge, rather than a barrier, but even more so after the Nazis invaded Poland. To the Corps' strategic bombing advocates, the lessons of the European war reinforced what they already believed:

**SPEED = SURVIVAL**

**RANGE = IMPACT**

**BOMB LOAD = *VICTORY***

# FIGHT WITH WHAT YOU HAVE

It would be two more years before American production hit full stride, but by 1942 the AAF already had two heavy bomber programs well in hand:



# FIGHT WITH WHAT YA'II SOON HAVE

And another ambitious program ramping up:

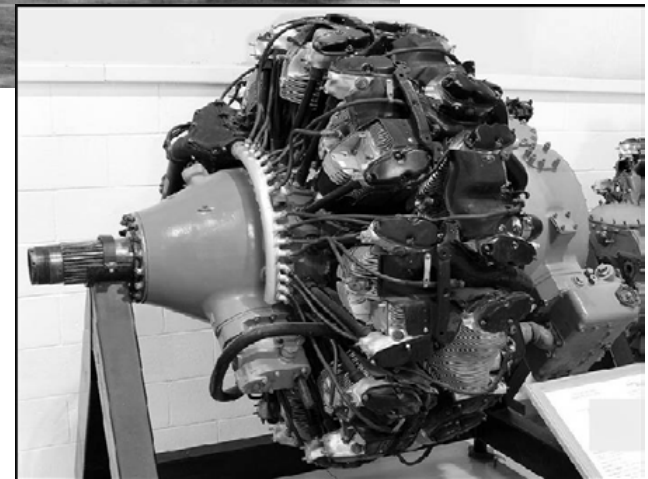



# THE ISSUE RESURFACES...WHAT IF?

**All three bomber programs were expected to use overseas bases—in England, the Far East, and the Pacific. But in 1941-1942, it was not at all certain that those bases would remain in safe hands and available for American use...**

# THE ISSUE RESURFACES...WHAT IF?

All three bomber programs were expected to use overseas bases—in England, the Far East, and the Pacific. But in 1941-1942, it was not at all certain that those bases would remain in safe hands and available for American use...

**VICTORY IS ALWAYS THE GOAL, BUT IT ONLY BECOMES INEVITABLE AFTER THE FACT.**

# THE ISSUE RESURFACES...WHAT IF?

The Air Corps had already procured two ultra-heavy bombers for conducting possible “Hemispheric Defense” efforts from American soil...both ‘one-offs’ were failures.



# THE ISSUE RESURFACES...WHAT IF?

**In 1941, it held a third ultra-heavy bomber competition. Boeing lost to Consolidated-Vultee; first deliveries were expected in 1944...**

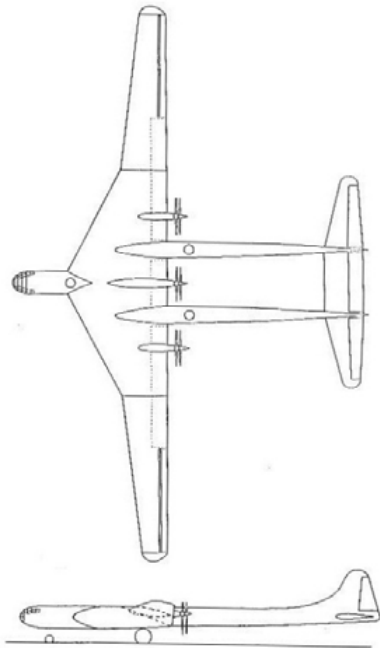

# THE ISSUE RESURFACES...WHAT IF?

But Boeing didn't give up. In 1942, the AAF's Air Materiel Command (AMC) awarded Boeing several contracts to conduct further studies...

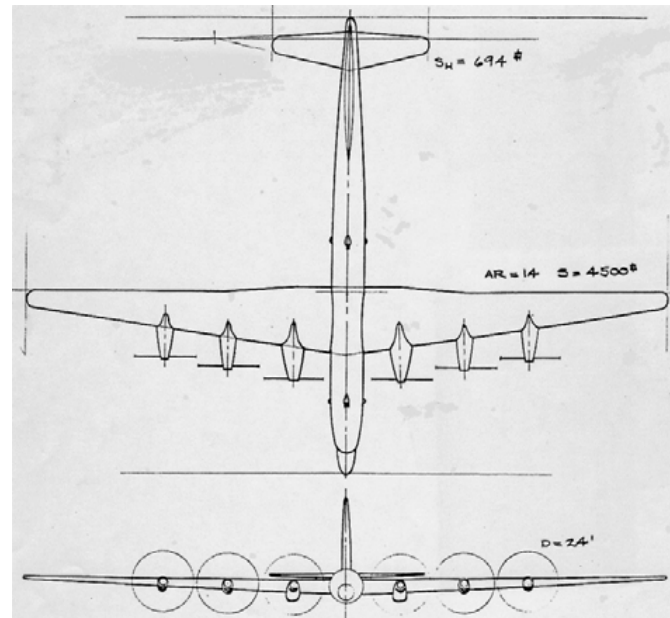
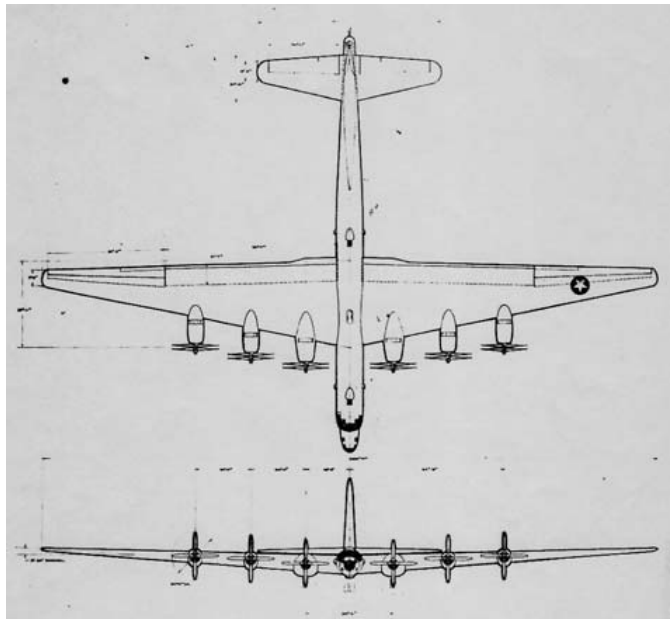

# THE ISSUE RESURFACES...WHAT IF?

Not to be outdone, Consolidated-Vultee also conducted additional research in 1942, 'just in case'...

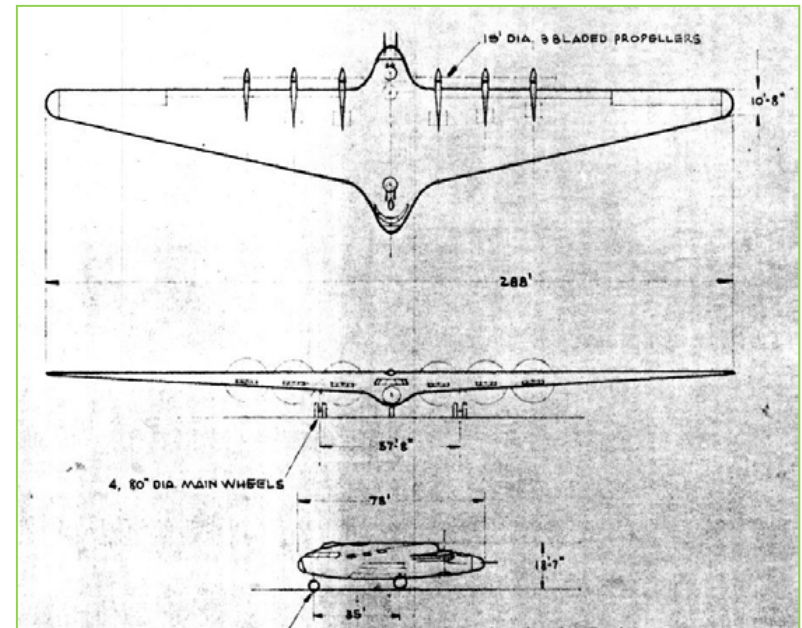
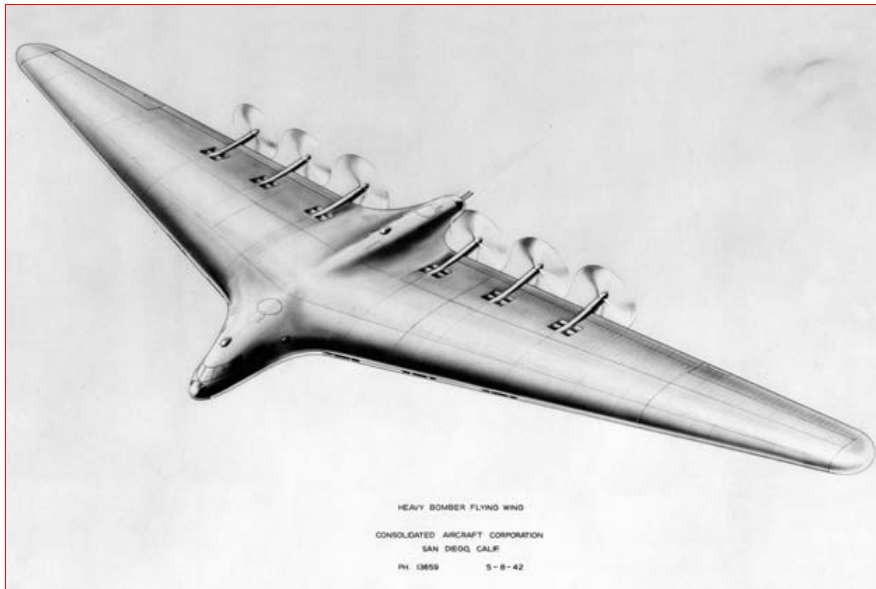

# THE ISSUE RESURFACES...WHAT IF?

**Boeing fought back in 1943 with a 'last gasp' proposal for its own flying wing...**

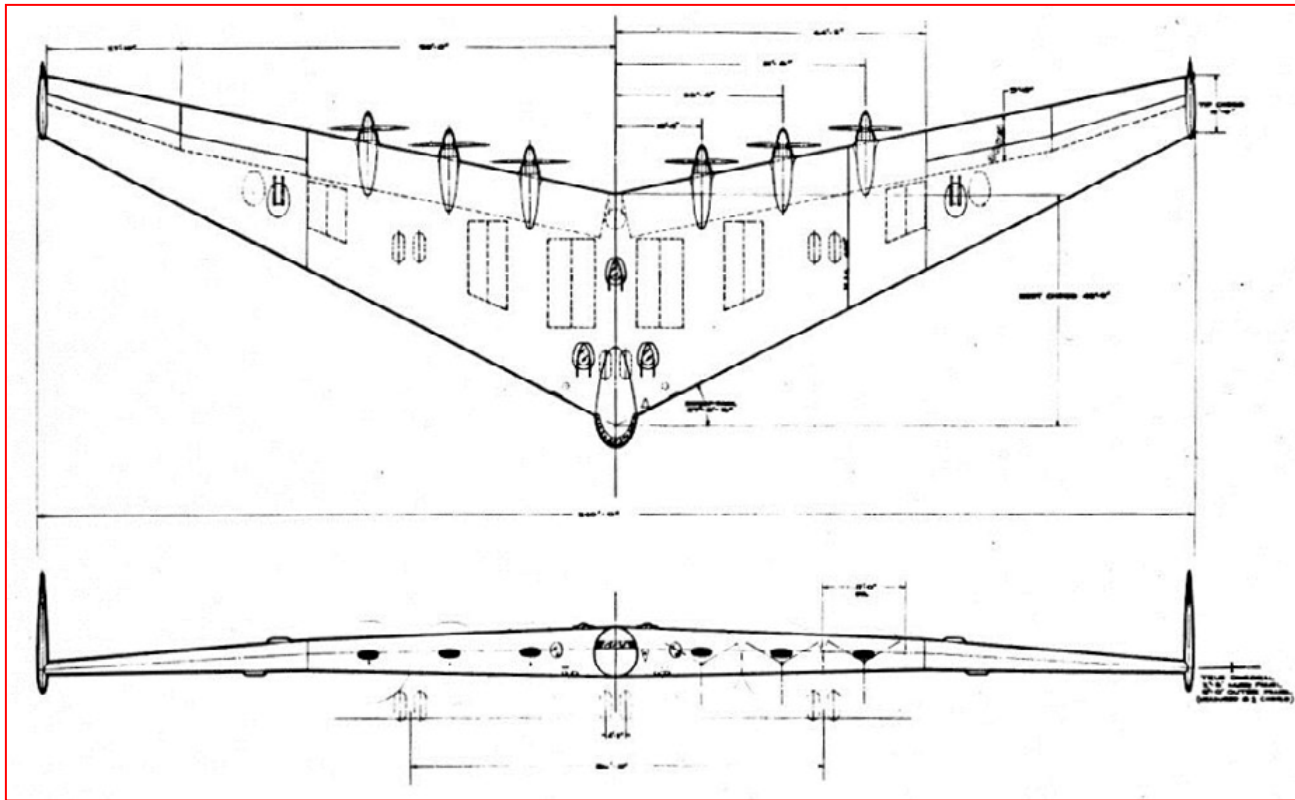

# AMC DOUBLES DOWN...

AMC rejected the Boeing design, declaring that it was “too conservative.” Instead, *this* is what AMC’s in-house engineers had in mind:

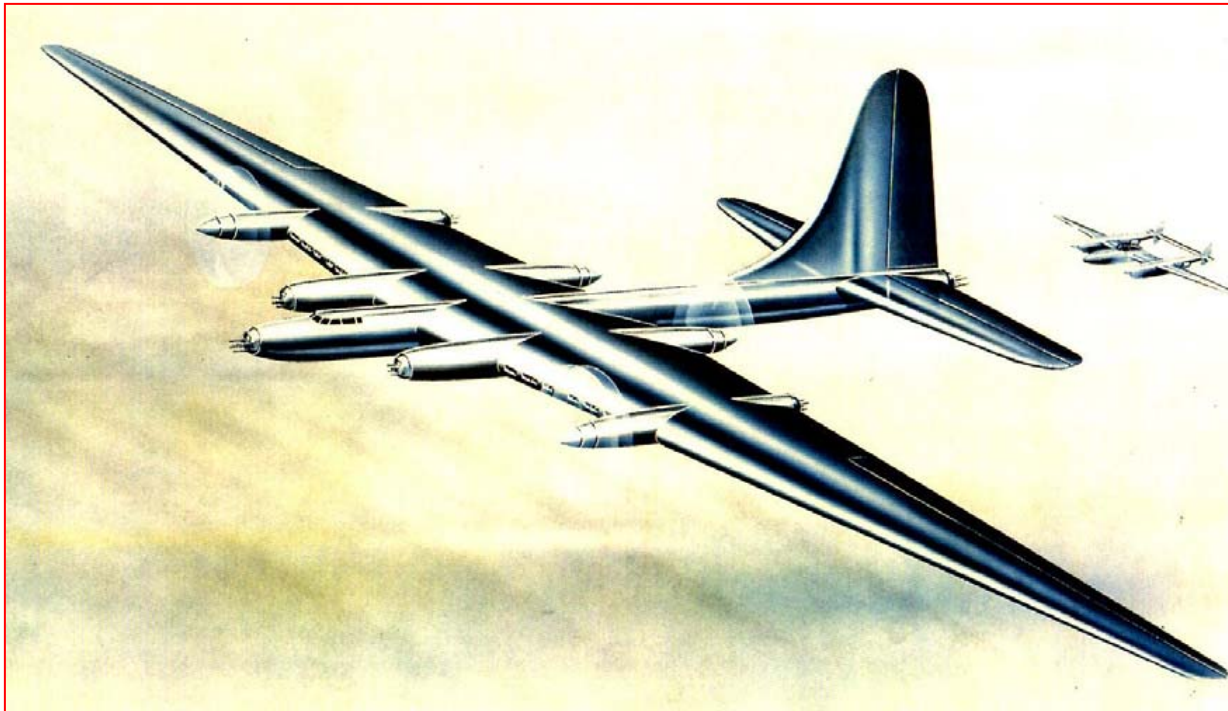



# AMC DOUBLES DOWN...

**M.C.D. 392 specs featured up to 12 engines, a gross weight of up to 655,000 lbs. and a 321' wingspan, and a crew of no less than 14 men...**

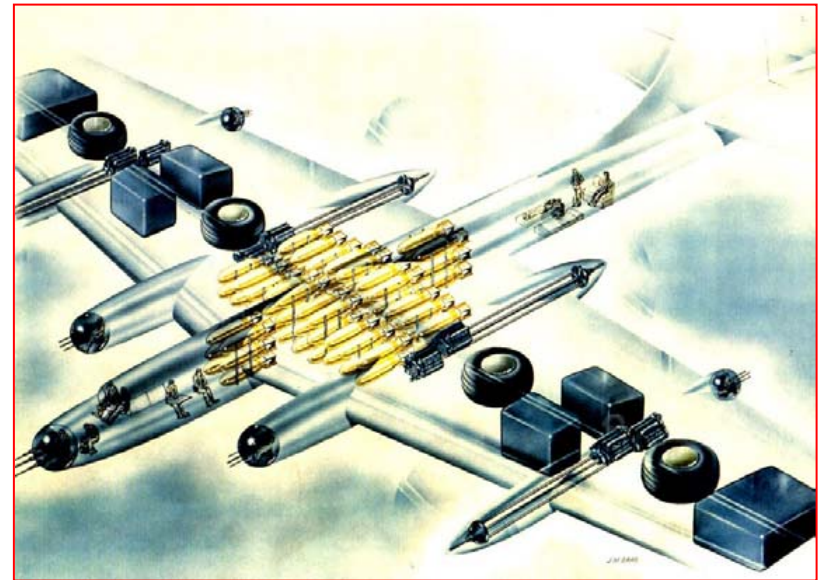
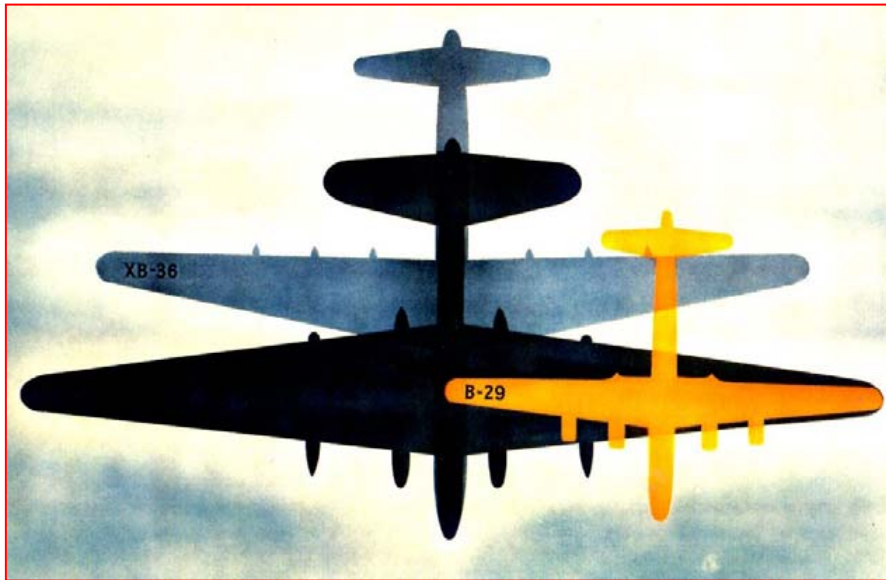

# END GAME

As always, the weak(est) link in such monster designs was the lack of a reliable engine with sufficient output...

